

ControlMaster CM10, CM30, CM50, CMF160 and CMF310

Universal process controllers, 1/8, 1/4, 1/2 DIN and fieldmount



Measurement made easy

For more information

Further publications for the ControlMaster controllers and indicators are available for free download from:

www.abb.com/measurement

or by scanning this code:



Search for or click on

Data Sheet
ControlMaster CM10
Universal process controller, 1/8 DIN [DS/CM10-EN](#)

Data Sheet
ControlMaster CM30
Universal process controller, 1/4 DIN [DS/CM30-EN](#)

Data Sheet
ControlMaster CM50
Universal process controller, 1/2 DIN [DS/CM50-EN](#)

Data Sheet
ControlMaster CMF310
Universal process controller, fieldmount [DS/CMF310-EN](#)

Data Sheet
ControlMaster CMF160
Universal process indicator, fieldmount [DS/CMF160-EN](#)

Search for or click on

Data Sheet
ControlMaster CM15
Universal process indicator, 1/8 DIN [DS/CM15-EN](#)

User Guide – Basic Functionality
ControlMaster CM10, CM30 and CM50
Universal process controllers, 1/8, 1/4 and 1/2 DIN [IM/CM/B-EN](#)

User Guide – Standard Functionality
ControlMaster CM10, CM30 and CM50
Universal process controllers, 1/8, 1/4 and 1/2 DIN [IM/CM/S-EN](#)

User Guide – Extended/Dual Functionality
ControlMaster CM30, CM50 and CMF310
Universal process controllers, 1/4, 1/2 DIN and fieldmount [IM/CM/ED-EN](#)

User Guide
ControlMaster CM15 and CMF160
Universal process indicator and fieldmount [IM/CM/I-EN](#)

Contents

1 Safety	3	6 MODBUS Tables	19
1.1 Electrical Safety	3	6.1 Input Coils – Digital Inputs (MODBUS Function Code 02 [Read Input Status])	19
1.2 Symbols	3	6.2 Input Coils – Profile Registers (MODBUS Function Code 02 [Read Input Status])	21
1.3 Health & Safety	4	6.3 Write Only Coils (MODBUS Function Code 05 [Force Single Coil])	21
2 Introduction	5	6.4 Output Coils (MODBUS Function Code 01 [Read Coil Status] or 05 [Force Single Coil])	22
2.1 EC Directive 89/336/EEC	5	6.5 Input Registers (MODBUS Function Code 04 [Read Input Register])	22
3 Communication Overview	6	6.5.1 Read-only 32 Bits	22
3.1 Communication Options	6	6.5.2 Read-only Single Precision Float (MODBUS Function Code 04 [Read Input Register])	22
3.1.1 Ethernet	6	6.5.3 Input Registers For Bytes (MODBUS Function Code 04 [Read Input Registers])	24
3.1.2 RS 485 MODBUS	7		
4 Communication Level	8		
4.1 Communication	8		
5 MODBUS Communications	13		
5.1 Electrical Connections	13		
5.2 Host Computer Serial Communications	13		
5.3 Two-wire and Four-wire Connection	16		
5.4 Pull-up and Pull-down Resistors	17		
5.5 Termination Resistor	17		
5.6 Serial Connections	18		

6.6	Holding Registers (MODBUS Function Code 03 [Read Holding Register] or 06 [Write Holding Register])	24
6.6.1	Writable 16 Bits	24
6.6.2	Writable 32 Bits	24
6.6.3	Writable Single Precision Float	25
6.6.4	Profile	27
7	Ethernet Connections	28
7.1	CM10, CM15, CM30 and CM50	28
7.2	CMF160 and CMF310	29
8	Specification	30

1 Safety

Information in this manual is intended only to assist our customers in the efficient operation of our equipment. Use of this manual for any other purpose is specifically prohibited and its contents are not to be reproduced in full or part without prior approval of the Technical Publications Department.









1.1 Electrical Safety

This equipment complies with the requirements of CEI/IEC 61010-1:2001-2 'Safety Requirements for Electrical Equipment for Measurement, Control and Laboratory Use' and complies with US NEC 500, NIST and OSHA.

If the equipment is used in a manner NOT specified by the Company, the protection provided by the equipment may be impaired.

1.2 Symbols

One or more of the following symbols may appear on the equipment labelling:

	Warning – Refer to the manual for instructions		Direct current supply only
	Caution – Risk of electric shock		Alternating current supply only
	Functional earth (ground) terminal		Both direct and alternating current supply
	Protective earth (ground) terminal		The equipment is protected through double insulation

1.3 Health & Safety

Health and Safety

To ensure that our products are safe and without risk to health, the following points must be noted:

- The relevant sections of these instructions must be read carefully before proceeding.
- Warning labels on containers and packages must be observed.
- Installation, operation, maintenance and servicing must be carried out only by suitably trained personnel and in accordance with the information given.
- Normal safety precautions must be taken to avoid the possibility of an accident occurring when operating in conditions of high pressure and / or temperature.

Safety advice concerning the use of the equipment described in this manual or any relevant hazard data sheets (where applicable) may be obtained from the Company, together with servicing and spares information.

2 Introduction

This manual provides details for the ControlMaster CM10 (1/8 DIN), CM15 (1/8 DIN), CM30 (1/4 DIN), CM50 (1/2 DIN), CMF160 (fieldmount) and CMF310 (fieldmount) communication protocols, MODBUS connections and configuration tables and Ethernet connection details.

Note.

- Install and use associated equipment in accordance with the relevant national and local standards.
- System configuration must be carried out only by users or personnel with approved access rights (user privileges).
- Read all relevant sections of this guide before configuring the system or modifying system parameters.

2.1 EC Directive 89/336/EEC

In order to meet the requirements of the EC Directive 89/336/EEC for EMC regulations, this product must not be used in a non-industrial environment.

3 Communication Overview

Extensive communication options enable the ControlMaster to be integrated into larger control systems easily or connected to other process instrumentation.

3.1 Communication Options

3.1.1 Ethernet

Optional Ethernet communications enable the ControlMaster to be integrated in to an Ethernet network quickly.

The following functionality is provided:

- **Email**

Notification of a critical process event or status can be made by email. Multiple events can trigger an email that can be sent to multiple recipients.

- **Webserver**

ControlMaster's integrated webserver enables the current status of the process and controller to be viewed remotely using a standard web browser.

- **MODBUS TCP**

Process values and status can be communicated to and from the ControlMaster in real-time using MODBUS TCP, enabling it to be integrated easily into larger control systems or connected to a data recorder.

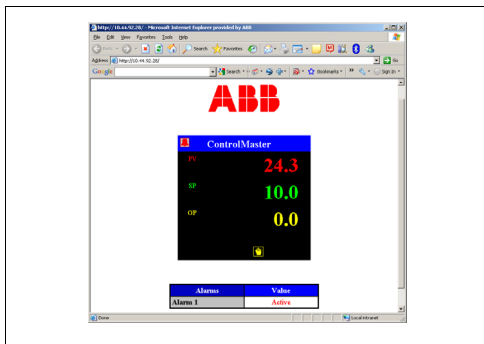

Fig. 3.1 Webserver

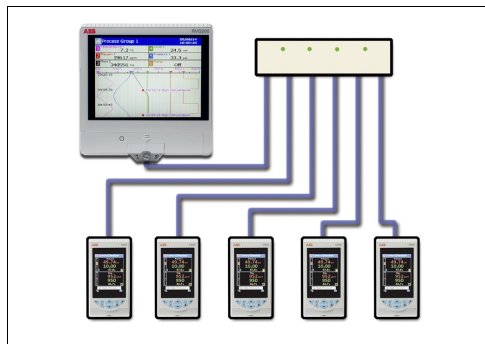

Fig. 3.2 ControlMasters connected to an RVG200

3.1.2 RS 485 MODBUS

Using RS 485 MODBUS, values and status can be communicated to and from the controller in real-time via an RS 485 connection.

4 Communication Level

4.1 Communication

The Communication parameters are accessed from the Advanced access level – refer to the User Guide supplied with your instrument for access details.

Note. *Communication* parameters are displayed for the type of communication board fitted in the instrument, for example, if a MODBUS board is fitted, MODBUS parameters are enabled, but Ethernet parameters are not enabled or displayed.

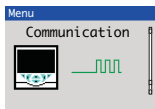

Used to setup communications parameters for the MODBUS / Ethernet / email communication protocols.

MODBUS

Refer to Section 5, page 13 for details of MODBUS coils and registers.

Device Address

The unique network address assigned to this device (1 to 247) that allows the host system to identify the instrument on a MODBUS link.

Reverse IEEE Data

All analog data is read from the instrument in IEEE (Institute of Electronics and Electrical Engineers) format contained in adjacent registers representing the data in high word / low word order.
Select Yes to reverse the IEEE data order, otherwise select No.

...Communication

RS485 Setup

Mode	Selects the MODBUS serial communication serial link as <i>2 Wire</i> , <i>4 Wire</i> or <i>Off</i> – see Section 5.3, page 16.
Baud Rate	A selectable communication transfer rate up to 115.2 K baud (bits per second) maximum (default 19200 baud).
Parity	Sets the parity bit (transmission error-checking) condition. Selected from: <ul style="list-style-type: none">■ No Parity■ Odd Parity■ Even Parity
Tx Delay	A set delay to the response from the transmitter in milliseconds. Maximum delay 100 ms.

...Communication

MODBUS TCP Setup	Note. After changing any of the TCP parameters it is advisable to power-cycle the instrument to ensure changes are applied.
Implementation	Select the MODBUS TCP operation mode: <ul style="list-style-type: none">■ Off – MODBUS TCP disabled■ Server – instrument acts as a MODBUS slave
Port	Displays the TCP/IP port used by the MODBUS TCP network (fixed at 502).
Connections	Select the maximum number of simultaneous TCP/IP connections permitted – minimum 1, maximum 3.
Client Authority	Select the number of authorized TCP/IP connections permitted: Selected from: <ul style="list-style-type: none">■ Unrestricted – any MODBUS TCP client device is permitted to poll the instrument■ 1 (to 3) – Only the MODBUS TCP client device whose IP address is entered in the authorized <i>Client 1 (to 3) IP</i> parameter (below) is permitted to poll the instrument.
Client 1 (to 3) IP	Enter the IP address(es) of the MODBUS TCP Client (MODBUS Master) device(s) permitted to poll the instrument for data. Note. Displayed only if the <i>Client Authority</i> parameter (above) is not set to <i>Unrestricted</i> .

...Communication

Ethernet

DHCP	Set <i>DHCP</i> (Dynamic Host Control Protocol) enable to <i>On</i> if the <i>IP address</i> is to be allocated dynamically by the network. Set to <i>Off</i> if the <i>IP address</i> is defined statically.
IP Address	Set the IP address to be assigned to the instrument. The IP address is used by the TCP/IP protocol to distinguish between different devices. The address is a 32-bit value expressed with 4 values (0 to 255), each separated by a period (.). Note. Configurable only if <i>DHCP</i> is disabled.
Subnet Mask	The subnet mask is used to indicate which part of the IP address is used for the network ID and which part is used for the host ID. Set each bit that is part of the network ID as '1's, for example: 255.255.255.0 indicates the first 24 bits are for the network ID.
Default Gateway	Note. This setting is only required if a router (or switch) is used. Sets the IP address for the Default Gateway (router or switch) used to communicate with other networks. The default setting is '000.000.000.000'.

...Communication

Email	
SMTP Server IP	The IP (Internet Protocol) address of the SMTP (Simple Mail Transport Protocol) server used to distribute emails.
Recipients	
Email Address 1(3)	Enter the email address(es) of the recipient(s).
Triggers	
Tag 1(4)	The trigger description that appears in the subject title.
Source 1(4)	Up to 4 independently configurable triggers can be enabled to generate an email when the selected source becomes active (the email can be sent to up to 3 recipients).
Invert 1(4)	If enabled, an email is generated when the <i>Source</i> becomes inactive instead of active.

5 MODBUS Communications

5.1 Electrical Connections

This section describes the connection of serial data cables between the master (host computer) and slave instrument on a MODBUS serial link.

5.2 Host Computer Serial Communications

The serial interface option module operates using the MODBUS Remote Terminal Unit (RTU) Master / Slave protocol. An appropriate RS422 / 485 communications driver must be fitted to the host (master) computer. It is strongly recommended that the interface has galvanic isolation to protect the computer from lightning damage and to increase signal immunity to noise pick-up.

Note. The MODBUS option provides the following facilities:

- Standard RS422/485 communications.
- MODBUS RTU protocol – the instrument is designed to operate as a Remote Terminal Unit (RTU) slave when communicating with a master (host) system.
- 500V DC isolation from external connections to the instrument.
- Two- or four-wire communication (selected at the *MODBUS / Mode* parameter) – see page 9.
- 1200, 2400, 4800, 9600, 19200, 38400, or 115200 baud transmission rate – see page 9.
- Parity-checking (odd, even or none) – see page 9.

Warning.

- ControlMaster controllers and indicator are not fitted with a switch therefore a disconnecting device such as a switch or circuit breaker conforming to local safety standards must be fitted to the final installation.
- It must be mounted in close proximity to the ControlMaster within easy reach of the operator and must be marked clearly as the disconnection device for the instrument.
- Remove all power from supply, relay and any powered control circuits and high common mode voltages before accessing or making any connections.
- Use cable appropriate for the load currents. The terminals accept cables from 18 to 14 AWG (0.8 to 2.5mm²).
- Always route signal leads and power cables separately, preferably in earthed (grounded) metal conduit.
- It is strongly recommended that screened cable is used for signal inputs and relay connections.
- ControlMaster CM10, CM30 and CM50 controllers and CM15 indicator conform to Mains Power Input Overvoltage Category 2, Pollution Degree 2 (EN601010-1) and are protected through double insulation – Class II.
- ControlMaster CMF160 and CMF310 conform to Overvoltage Class III on mains, Class II on inputs and outputs and Pollution degree 2, Insulation class 1.
- Analog / digital inputs and outputs, transmitter power supply and DC power supply are SELV (Safety Extra Low Voltage) circuits.
- All connections to secondary circuits must have basic insulation.
- After installation, there must be no access to live parts, e.g. terminals.
- Terminals for external circuits are for use only with equipment with no accessible live parts.
- If a ControlMaster is used in a manner not specified by the Company, the protection provided by the equipment may be impaired.
- All equipment connected to the instrument's terminals must comply with local safety standards (IEC 60950, EN601010-1).

Note. Terminal screws must be tightened to a torque of 0.1 Nm (0.9 lbf/in.).

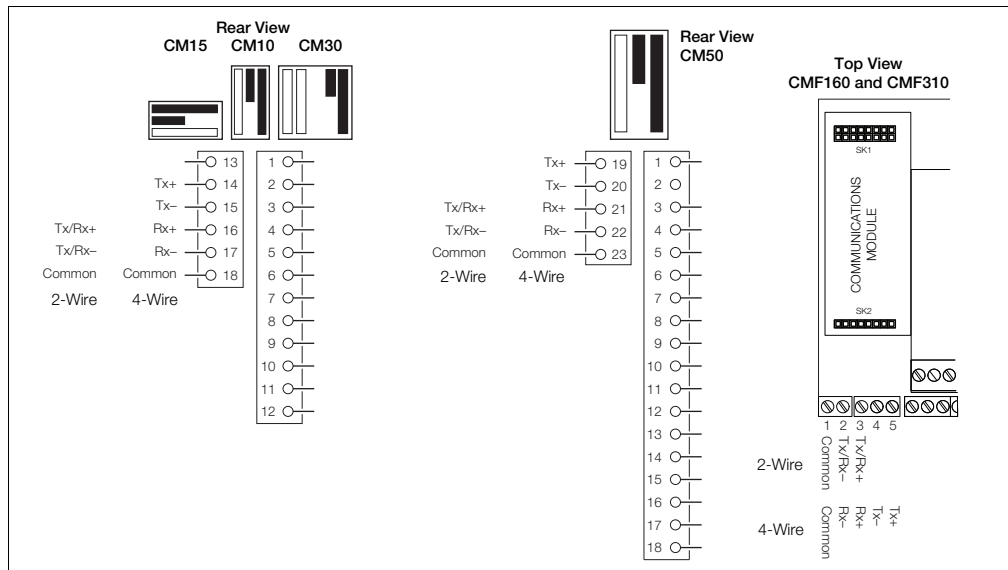

Fig. 5.1 Connections Overview

5.3 Two-wire and Four-wire Connection

MODBUS serial communications can be configured as either 2-wire or 4-wire serial links – see Fig. 5.2. The instrument must be added to the link configuration on the host system – refer to information supplied with the host system.

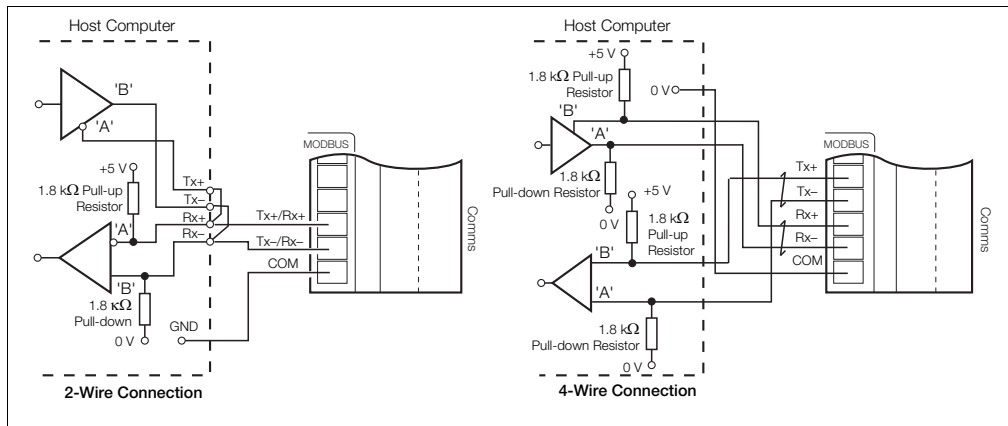

Fig. 5.2 2-Wire and 4-Wire MODBUS Serial Links

5.4 Pull-up and Pull-down Resistors

To prevent false triggering of slaves when the master (host computer) is inactive, pull-up and pull-down resistors must be fitted to the RS422/485 interface in the host computer.

Resistors are normally connected to the interface by hard-wired links or switches – refer to the manufacturer's instructions

5.5 Termination Resistor

For long transmission lines, 120 Ω termination resistors must be fitted to the last slave in the chain and the master receive – see Fig. 5.3.

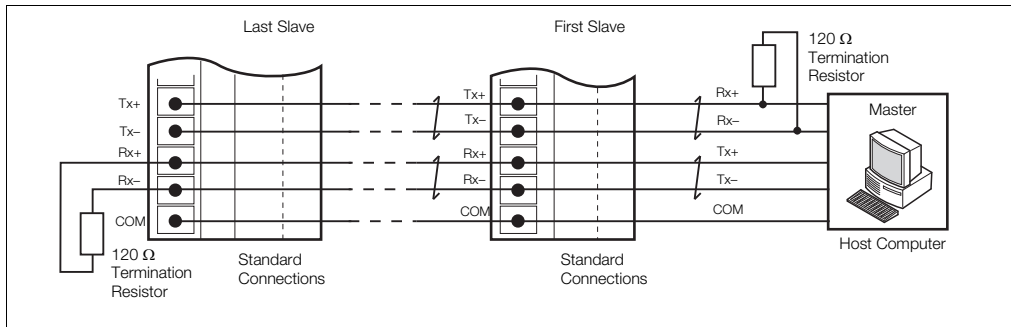

Fig. 5.3 Connecting Multiple Slaves

5.6 Serial Connections

Connections to the MODBUS serial board must be made as shown in Fig. 5.2. Connections to two- or four-wire link configurations on systems with multiple slaves must be made in parallel as shown in Fig. 5.3. When connecting cable screens, ensure that ground loops are not introduced.

The maximum serial data transmission line length for both RS422 and RS485 systems is 1200 m (3937 ft.).

The types of cable that can be used are determined by the total line length:

- Up to 6 m (19.7 ft.) – standard screened or twisted pair cable.
- Up to 300 m (984 ft.) – twin twisted pair with overall foil screen and an integral drain wire.
- Up to 1200 m (3937 ft.) – twin twisted pair with separate foil screens and integral drain wires.

6 MODBUS Tables

Note. The tables in Section 6 contain MODBUS register numbers, not PDU addresses.

6.1 Input Coils – Digital Inputs (MODBUS Function Code 02 [Read Input Status])

MODBUS Coil	Title
1	Analog Input 1 Fail
2	Analog Input 2 Fail
3	Analog Input 3 Fail
4	Analog Input 4 Fail
5	Analog Input 1 (digital) Value
6	Analog Input 2 (digital) Value
7	Analog Input 3 (digital) Value
8	Analog Input 4 (digital) Value
9	Math Block 1 Fail
10	Math Block 2 Fail
11	Math Block 3 Fail
12	Math Block 4 Fail
13	Math Block 5 Fail
14	Math Block 6 Fail
15	Math Block 7 Fail
16	Math Block 8 Fail

MODBUS Coil	Title
17	Custom Linearizer 1 Fail
18	Custom Linearizer 2 Fail
19	Loop 1 Setpoint 1 Active
20	Loop 2 Setpoint 1 Active
21	Loop 1 Setpoint 2 Active
22	Loop 2 Setpoint 2 Active
23	Loop 1 Setpoint 3 Active
24	Loop 2 Setpoint 3 Active
25	Loop 1 Setpoint 4 Active
26	Loop 2 Setpoint 4 Active
27	Digital Output 1
28	Digital Output 2
29	Digital Output 3
30	Digital Output 4
31	Digital Output 5
32	Digital Output 6

ControlMaster CM10, CM15, CM30, CM50, CMF160 and CMF310

Universal process controllers and indicator, 1/8, 1/4, 1/2 DIN and fieldmount

6 MODBUS Tables

MODBUS Coil	Title
33	Relay 1
34	Relay 2
35	Relay 3
36	Relay 4
37	Totalizer 1 Intermediate Pulse
38	Totalizer 1 Wrap Pulse
39	Totalizer 2 Intermediate Pulse
40	Totalizer 2 Wrap Pulse
41	Logic Equation 1 State
42	Logic Equation 2 State
43	Logic Equation 3 State
44	Logic Equation 4 State
45	Logic Equation 5 State
46	Logic Equation 6 State
47	Logic Equation 7 State
48	Logic Equation 8 State
49	Realtime Alarm 1 State
50	Realtime Alarm 2 State
51	Alarm 1 State
52	Alarm 1 Ack State
53	Alarm 2 State
54	Alarm 2 Ack State
55	Alarm 3 State

MODBUS Coil	Title
56	Alarm 3 Ack State
57	Alarm 4 State
58	Alarm 4 Ack State
59	Alarm 5 State
60	Alarm 5 Ack State
61	Alarm 6 State
62	Alarm 6 Ack State
63	Alarm 7 State
64	Alarm 7 Ack State
65	Alarm 8 State
66	Alarm 8 Ack State
67	Loop Break 1 State
68	Loop Break 2 State
69	Delay Timer 1 State
70	Delay Timer 2 State
89	Motorized Valve Output 1 Relay Close State
90	Motorized Valve Output 1 Relay Open State
91	Motorized Valve Output 1 Valve Sticking State
92	Motorized Valve Output 2 Relay Close State
93	Motorized Valve Output 2 Relay Open State
94	Motorized Valve Output 2 Valve Sticking State
95	Loop 1 Autotune In Progress
96	Loop 2 Autotune In Progress

6.2 Input Coils – Profile Registers (MODBUS Function Code 02 [Read Input Status])

MODBUS Coil	Title
144	Program Event 1
145	Program Event 2
146	Program Event 3
147	Program Event 4
148	Program Event 5
149	Program Event 6
150	Program Event 7
151	Program Event 8
152	PV Event
153	Timed Event
154	Profile Run State
155	Profile Hold State
156	Profile Hold back
157	Profile Wait
158	Program Reset
159	Program End

6.3 Write Only Coils (MODBUS Function Code 05 [Force Single Coil])

MODBUS Coil	Title
101	Totalizer 1 Batch Total Reset
102	Totalizer 2 Batch Total Reset
103	Totalizer 1 Secure Total Reset
104	Totalizer 2 Secure Total Reset

6.4 Output Coils (MODBUS Function Code 01 [Read Coil Status] or 05 [Force Single Coil])

MODBUS Coil	Title
1	Loop 1 Auto/Manual State 0 = Auto, 1 = Man
2	Loop 2 Auto/Manual State 0 = Auto, 1 = Man
3	Loop 1 Setpoint Mode 0 = Local, 1 = Remote
4	Loop 2 Setpoint Mode 0 = Local, 1 = Remote
5	Totalizer 1 Run State
6	Totalizer 2 Run State
7	Loop 1 Tracking State
8	Loop 2 Tracking State

6.5 Input Registers (MODBUS Function Code 04 [Read Input Register])

6.5.1 Read-only 32 Bits

MODBUS Register	Title
4001	Totalizer 1 Batch Total
4003	Totalizer 2 Batch Total
4005	Totalizer 1 Secure Total
4007	Totalizer 2 Secure Total

6.5.2 Read-only Single Precision Float (MODBUS Function Code 04 [Read Input Register])

MODBUS Register	Title
5001	Analog I/P 1 Value
5003	Analog I/P 2 Value
5005	Analog I/P 3 Value
5007	Analog I/P 4 Value
5009	Loop 1 Process Variable
5011	Loop 2 Process Variable
5013	Loop 1 Control Output
5015	Loop 2 Control Output
5029	Loop 1 Deviation
5031	Loop 2 Deviation
5033	Loop 1 Feedforward Value

ControlMaster CM10, CM15, CM30, CM50, CMF160 and CMF310

Universal process controllers and indicator, 1/8, 1/4, 1/2 DIN and fieldmount

6 MODBUS Tables

MODBUS Register	Title
5035	Loop 2 Feedforward Value
5041	Loop 1 Manual Valve Output
5045	Loop 2 Manual Valve Output
5043	Loop 1 Actual Valve Position
5047	Loop 2 Actual Valve Position
5049	Loop 1 Actual Ratio
5051	Loop 2 Actual Ratio
5053	Loop 1 Remote Setpoint
5055	Loop 2 Remote Setpoint
5057	Loop 1 Split Output 1
5059	Loop 1 Split Output 2
5061	Loop 2 Split Output 1
5063	Loop 2 Split Output 2
5065	Process Variable 1 Max
5067	Process Variable 2 Max
5069	Process Variable 1 Min
5071	Process Variable 2 Min
5073	Process Variable 1 Ave
5075	Process Variable 2 Ave
5077	Volume 1
5079	Volume 2
5081	Custom Linearizer 1 Value
5083	Custom Linearizer 2 Value
5085	Math Block 1 Result

MODBUS Register	Title
5087	Math Block 2 Result
5089	Math Block 3 Result
5091	Math Block 4 Result
5093	Math Block 5 Result
5095	Math Block 6 Result
5097	Math Block 7 Result
5099	Math Block 8 Result
5101	Loop 1 Active Local Setpoint
5103	Loop 2 Active Local Setpoint
5105	Loop 1 Control Setpoint
5107	Loop 2 Control Setpoint

6.5.3 Input Registers For Bytes (MODBUS Function Code 04 [Read Input Registers])

MODBUS Register	Title
0001	Output 1
0002	Output 2
0003	Instrument Type
0004	Instrument I/O build
0005	Instrument Functionality

6.6 Holding Registers (MODBUS Function Code 03 [Read Holding Register] or 06 [Write Holding Register])

6.6.1 Writable 16 Bits

MODBUS Register	Title
2001	Alarm 1 Time Hysteresis
2002	Alarm 2 Time Hysteresis
2003	Alarm 3 Time Hysteresis
2004	Alarm 4 Time Hysteresis
2005	Alarm 5 Time Hysteresis
2006	Alarm 6 Time Hysteresis
2007	Alarm 7 Time Hysteresis
2008	Alarm 8 Time Hysteresis

6.6.2 Writable 32 Bits

MODBUS Register	Title
6001	Totalizer 1 Preset Value
6003	Totalizer 1 Predetermined Value
6005	Totalizer 1 Intermediate Value
6007	Totalizer 2 Preset Value
6009	Totalizer 2 Predetermined Value
6011	Totalizer 2 Intermediate Value

6.6.3 Writable Single Precision Float

MODBUS Register	Title
6591	Alarm 1 Trip
6593	Alarm 1 Hysteresis
6595	Alarm 2 Trip
6597	Alarm 2 Hysteresis
6599	Alarm 3 Trip
6601	Alarm 3 Hysteresis
6603	Alarm 4 Trip
6605	Alarm 4 Hysteresis
6607	Alarm 5 Trip
6609	Alarm 5 Hysteresis
6611	Alarm 6 Trip
6613	Alarm 6 Hysteresis
6615	Alarm 7 Trip
6617	Alarm 7 Hysteresis
6619	Alarm 8 Trip
6621	Alarm 8 Hysteresis
6639	Loop 1 Local Setpoint 1
6641	Loop 1 Local Setpoint 2
6643	Loop 1 Local Setpoint 3
6645	Loop 1 Local Setpoint 4

MODBUS Register	Title
6647	Loop 1 Remote Setpoint Ratio
6649	Loop 1 Remote Setpoint Bias
6661	Loop 2 Local Setpoint 1
6663	Loop 2 Local Setpoint 2
6665	Loop 2 Local Setpoint 3
6667	Loop 2 Local Setpoint 4
6669	Loop 2 Remote Setpoint Ratio
6671	Loop 2 Remote Setpoint Bias
6673	Default Setpoint
6685	Loop 1 Default Output
6687	Loop 1 Configured Output 1
6689	Loop 1 Configured Output 2
6703	Loop 2 Default Output
6705	Loop 2 Configured Output 1
6707	Loop 2 Configured Output 2
6715	Loop 1 Output 1 Cycle Time
6717	Loop 1 Output 2 Cycle Time
6719	Loop 2 Output 1 Cycle Time
6721	Loop 2 Output 2 Cycle Time
6727	Loop 1 Valve Ratio
6729	Loop 1 Valve Bias
6731	Loop 1 Valve Deadband

MODBUS Register	Title
6733	Loop 2 Valve Ratio
6735	Loop 2 Valve Bias
6737	Loop 2 Valve Deadband
6779	Loop 1 Proportional Band 1
6781	Loop 1 Integral Time 1
6783	Loop 1 Derivative Time 1
6785	Loop 1 Proportional Band 2
6787	Loop 1 Integral Time 2
6789	Loop 1 Derivative Time 2
6791	Loop 1 Proportional Band 3
6793	Loop 1 Integral Time 3
6795	Loop 1 Derivative Time 3
6797	Loop 1 Manual Reset
6803	Loop 1 Feedforward Gain
6817	Loop 2 Proportional Band 1
6819	Loop 2 Integral Time 1
6821	Loop 2 Derivative Time 1
6823	Loop 2 Proportional Band 2
6825	Loop 2 Integral Time 2
6827	Loop 2 Derivative Time 2
6829	Loop 2 Proportional Band 3
6831	Loop 2 Integral Time 3
6833	Loop 2 Derivative Time 3
6835	Loop 2 Manual Reset

MODBUS Register	Title
6837	Loop 2 Feedforward Gain
7111	Math Block Constant 1
7113	Math Block Constant 2
7115	Math Block Constant 3
7117	Math Block Constant 4
7119	Math Block Constant 5
7121	Math Block Constant 6
7123	Math Block Constant 7
7125	Math Block Constant 8
7147	Loop 1 Control Output
7149	Loop 2 Control Output

6.6.4 Profile

MODBUS Register	Title
851	Profile Run
852	Program Number
853	Loop 1 Auto/Manual
854	Loop 2 Auto/Manual

Note. For further MODBUS registers contact your local ABB representative.

7 Ethernet Connections

7.1 CM10, CM15, CM30 and CM50

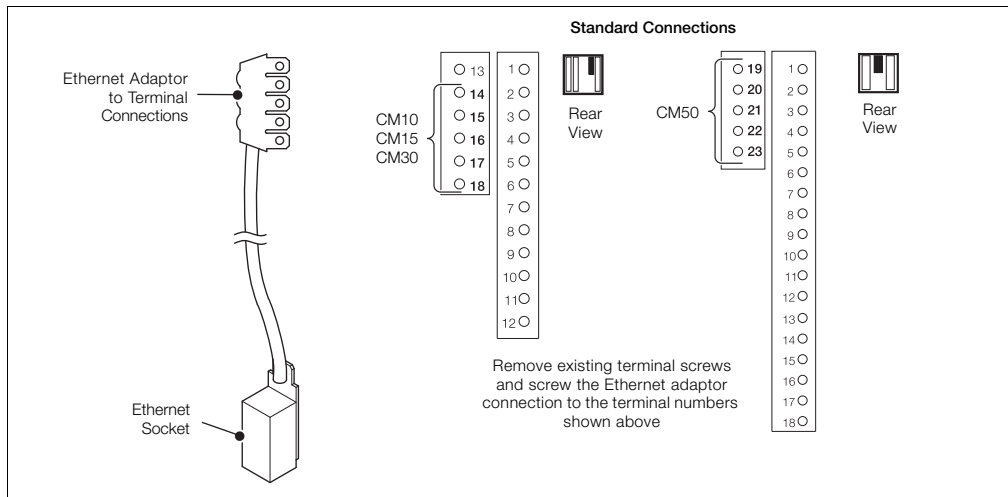

7.2 CMF160 and CMF310

Note.

- Isolate the instrument from the power supply before removing the terminal cover.
- Fit cable gland to ethernet cable to maintain IP rating as required.

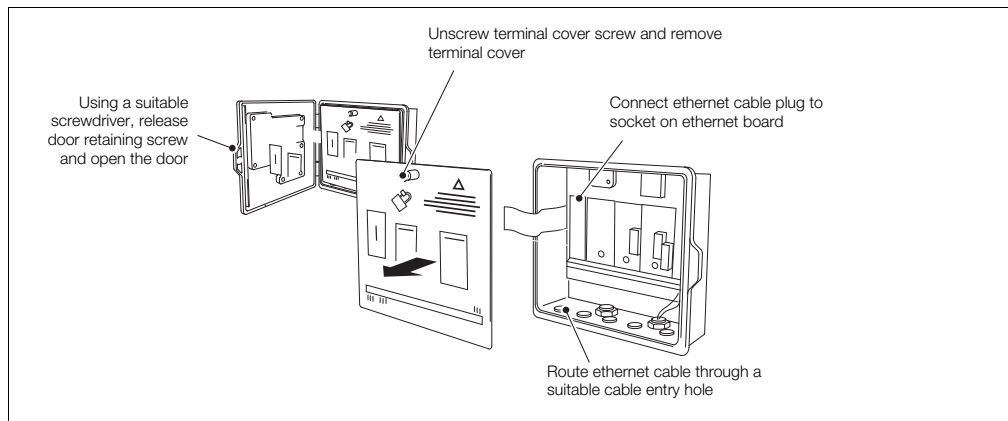

8 Specification

Communications

Note. Only 1 optional communications board can be fitted per controller.

MODBUS¹ RTU (optional)

Baud rate	Up to 115 k Baud
Isolation	Galvanically isolated from the rest of the circuitry, 500 V DC for 1 minute

Ethernet (optional)

Type	10Base T
Connector	RJ45
Protocols	TCP/IP HTTP MODBUS TCP (slave)
Web server	Built-in, enables remote monitoring using standard web browsers
Email	Can be configured to be sent on the occurrence of a specified event Up to 3 recipients Up to 4 trigger sources with configurable tag

1. MODBUS is a registered trademark of the MODBUS-IDA organization

Sales



Service



Software



ABB Limited**Measurement & Analytics**

Howard Road, St. Neots
Cambridgeshire, PE19 8EU
UK

Tel: +44 (0)1480 475 321

Fax: +44 (0)1480 217 948

Email: instrumentation@gb.abb.com

ABB Inc.**Measurement & Analytics**

125 E. County Line Road
Warminster
PA 18974
USA

Tel: +1 215 674 6000

Fax: +1 215 674 7183

abb.com/measurement

We reserve the right to make technical changes or modify the contents of this document without prior notice. With regard to purchase orders, the agreed particulars shall prevail. ABB does not accept any responsibility whatsoever for potential errors or possible lack of information in this document.

We reserve all rights in this document and in the subject matter and illustrations contained therein. Any reproduction, disclosure to third parties or utilization of its contents – in whole or in parts – is forbidden without prior written consent of ABB.
© ABB 2018