

Communications Supplement IM/CM/C-EN Rev. D

ControlMaster CM10, CM15, CM30 and CM50

Universal process controllers and indicators, 1/8, 1/4 and 1/2 DIN



Power and productivity
for a better world™ **ABB**

The Company

We are an established world force in the design and manufacture of instrumentation for industrial process control, flow measurement, gas and liquid analysis and environmental applications.

As a part of ABB, a world leader in process automation technology, we offer customers application expertise, service and support worldwide.

We are committed to teamwork, high quality manufacturing, advanced technology and unrivalled service and support.

The quality, accuracy and performance of the Company's products result from over 100 years experience, combined with a continuous program of innovative design and development to incorporate the latest technology.

Contents

1 Safety	2	6 MODBUS Tables	18
1.1 Electrical Safety	2	6.1 Input Coils – Digital Inputs	18
1.2 Symbols	2	6.2 Output Coils	19
1.3 Health & Safety	3	6.3 Input Registers	20
2 Introduction	4	6.3.1 Read-only 32 Bits	20
2.1 EC Directive 89/336/EEC	4	6.3.2 Read-only Single Precision Float	20
3 Communication Overview	5	6.3.3 Input Registers For Bytes	21
3.1 Communication Options	5	6.4 Holding Registers	21
3.1.1 Ethernet	5	6.4.1 Writable 16 Bits	21
3.1.2 RS 485 MODBUS	6	6.4.2 Writable 32 Bits	22
3.2 PC Configuration	7	6.4.3 Writable Single Precision Float	22
4 Communication Level	8	7 Ethernet Connections	24
4.1 Communication	8	8 Specification	25
5 MODBUS Communications	13	Notes	26
5.1 Electrical Connections	13		
5.2 Host Computer Serial Communications	13		
5.3 Two-wire and Four-wire Connection	15		
5.4 Pull-up and Pull-down Resistors	16		
5.5 Termination Resistor	16		
5.6 Serial Connections	17		

1 Safety

Information in this manual is intended only to assist our customers in the efficient operation of our equipment. Use of this manual for any other purpose is specifically prohibited and its contents are not to be reproduced in full or part without prior approval of the Technical Publications Department.





1.1 Electrical Safety





This equipment complies with the requirements of CEI/IEC 61010-1:2001-2 'Safety Requirements for Electrical Equipment for Measurement, Control and Laboratory Use' and complies with US NEC 500, NIST and OSHA.

If the equipment is used in a manner NOT specified by the Company, the protection provided by the equipment may be impaired.

1.2 Symbols

One or more of the following symbols may appear on the equipment labelling:

	Warning – Refer to the manual for instructions
	Caution – Risk of electric shock
	Functional earth (ground) terminal
	Protective earth (ground) terminal

	Direct current supply only
	Alternating current supply only
	Both direct and alternating current supply
	The equipment is protected through double insulation

1.3 Health & Safety

Health and Safety

To ensure that our products are safe and without risk to health, the following points must be noted:

- The relevant sections of these instructions must be read carefully before proceeding.
- Warning labels on containers and packages must be observed.
- Installation, operation, maintenance and servicing must be carried out only by suitably trained personnel and in accordance with the information given.
- Normal safety precautions must be taken to avoid the possibility of an accident occurring when operating in conditions of high pressure and / or temperature.

Safety advice concerning the use of the equipment described in this manual or any relevant hazard data sheets (where applicable) may be obtained from the Company, together with servicing and spares information.

2 Introduction

This manual provides details for the ControlMaster CM10 (1/8 DIN), CM15 (1/8 DIN), CM30 (1/4 DIN) and CM50 (1/2 DIN) communication protocols, MODBUS connections and configuration tables and Ethernet connection details.

Note.

- Install and use associated equipment in accordance with the relevant national and local standards.
- System configuration must be carried out only by users or personnel with approved access rights (user privileges).
- Read all relevant sections of this guide before configuring the system or modifying system parameters.

2.1 EC Directive 89/336/EEC

In order to meet the requirements of the EC Directive 89/336/EEC for EMC regulations, this product must not be used in a non-industrial environment.

3 Communication Overview

Extensive communication options enable the ControlMaster to be integrated into larger control systems easily or connected to other process instrumentation.

3.1 Communication Options

3.1.1 Ethernet

Optional Ethernet communications enable the ControlMaster to be integrated in to an Ethernet network quickly.

The following functionality is provided:

- **Email**

Notification of a critical process event or status can be made by email. Multiple events can trigger an email that can be sent to multiple recipients.

- **Webserver**

ControlMaster's integrated webserver enables the current status of the process and controller to be viewed remotely using a standard web browser.

- **MODBUS TCP**

Process values and status can be communicated to and from the ControlMaster in real-time using MODBUS TCP, enabling it to be integrated easily into larger control systems or connected to a data recorder.

ControlMaster CM10, CM15, CM30 and CM50

Universal process controllers and indicators, 1/8, 1/4 and 1/2 DIN

3 Communication Overview

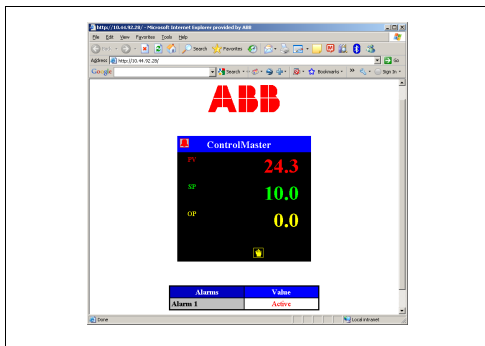

Fig. 3.1 Webservice

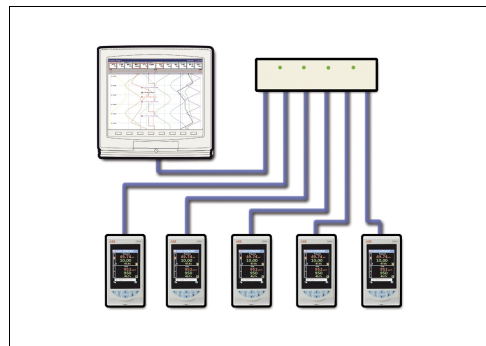

Fig. 3.2 ControlMasters connected to a ScreenMaster

3.1.2 RS 485 MODBUS

Using RS 485 MODBUS, values and status can be communicated to and from the controller in real-time via an RS 485 connection.

3.2 PC Configuration

In addition to configuration via the front panel, the ControlMaster can be configured from a PC via the infrared port (configuration files can be stored locally on a PC and transferred to the controller via the infrared port).

For further information contact your sales representative.

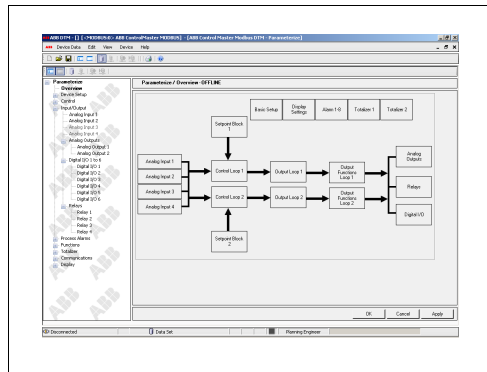

Fig. 3.3 PC Configuration Software

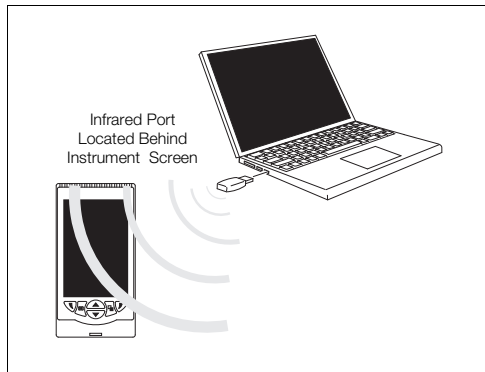

Fig. 3.4 Transferring a Configuration File via the Infrared Port

4 Communication Level

4.1 Communication

The Communication parameters are accessed from the Advanced access level – refer to the User Guide supplied with your instrument for access details.

Note. *Communication* parameters are displayed for the type of communication board fitted in the instrument, for example, if a MODBUS board is fitted, MODBUS parameters are enabled, but Ethernet parameters are not enabled or displayed.



Used to setup communications parameters for the MODBUS / Ethernet / email communication protocols.

MODBUS

Refer to Section 5, page 13 for details of MODBUS coils and registers.

Device Address

The unique network address assigned to this device (1 to 247) that allows the host system to identify the instrument on a MODBUS link.

Reverse IEEE Data

All analog data is read from the instrument in IEEE (Institute of Electronics and Electrical Engineers) format contained in adjacent registers representing the data in high word / low word order. Select Yes to reverse the IEEE data order, otherwise select No.

...Communication

RS485 Setup

Mode	Selects the MODBUS serial communication serial link as <i>2 Wire</i> , <i>4 Wire</i> or <i>Off</i> – see Section 5.3, page 15.
Baud Rate	A selectable communication transfer rate up to 115.2 K baud (bits per second) maximum (default 19200 baud).
Parity	Sets the parity bit (transmission error-checking) condition. Selected from: <ul style="list-style-type: none">■ No Parity■ Odd Parity■ Even Parity
Tx Delay	A set delay to the response from the transmitter in milliseconds. Maximum delay 100 ms.

...Communication

MODBUS TCP Setup	Note. After changing any of the TCP parameters it is advisable to power-cycle the instrument to ensure changes are applied.
Implementation	Select the MODBUS TCP operation mode: <ul style="list-style-type: none">■ Off – MODBUS TCP disabled■ Server – instrument acts as a MODBUS slave
Port	Displays the TCP/IP port used by the MODBUS TCP network (fixed at 502).
Connections	Select the maximum number of simultaneous TCP/IP connections permitted – minimum 1, maximum 3.
Client Authority	Select the number of authorized TCP/IP connections permitted: Selected from: <ul style="list-style-type: none">■ Unrestricted – any MODBUS TCP client device is permitted to poll the instrument■ 1 (to 3) – Only the MODBUS TCP client device whose IP address is entered in the authorized <i>Client 1 (to 3) IP</i> parameter (below) is permitted to poll the instrument.
Client 1 (to 3) IP	Enter the IP address(es) of the MODBUS TCP Client (MODBUS Master) device(s) permitted to poll the instrument for data. Note. Displayed only if the <i>Client Authority</i> parameter (above) is not set to <i>Unrestricted</i> .

...Communication

Ethernet

DHCP	Set <i>DHCP</i> (Dynamic Host Control Protocol) enable to <i>On</i> if the <i>IP address</i> is to be allocated dynamically by the network. Set to <i>Off</i> if the <i>IP address</i> is defined statically.
IP Address	Set the IP address to be assigned to the instrument. The IP address is used by the TCP/IP protocol to distinguish between different devices. The address is a 32-bit value expressed with 4 values (0 to 255), each separated by a period (.). Note. Configurable only if <i>DHCP</i> is disabled.
Subnet Mask	The subnet mask is used to indicate which part of the IP address is used for the network ID and which part is used for the host ID. Set each bit that is part of the network ID as '1's, for example: 255.255.255.0 indicates the first 24 bits are for the network ID.
Default Gateway	Note. This setting is only required if a router (or switch) is used. Sets the IP address for the Default Gateway (router or switch) used to communicate with other networks. The default setting is '000.000.000.000'.

...Communication

Email	
SMTP Server IP	The IP (Internet Protocol) address of the SMTP (Simple Mail Transport Protocol) server used to distribute emails.
Recipients	
Email Address 1(3)	Enter the email address(es) of the recipient(s).
Triggers	
Tag 1(4)	The trigger description that appears in the subject title.
Source 1(4)	Up to 4 independently configurable triggers can be enabled to generate an email when the selected source becomes active (the email can be sent to up to 3 recipients).
Invert 1(4)	If enabled, an email is generated when the <i>Source</i> becomes inactive instead of active.

5 MODBUS Communications

5.1 Electrical Connections

This section describes the connection of serial data cables between the master (host computer) and slave instrument on a MODBUS serial link.

5.2 Host Computer Serial Communications

The serial interface option module operates using the MODBUS Remote Terminal Unit (RTU) Master / Slave protocol. An appropriate RS422 / 485 communications driver must be fitted to the host (master) computer. It is strongly recommended that the interface has galvanic isolation to protect the computer from lightning damage and to increase signal immunity to noise pick-up.

Note. The MODBUS option provides the following facilities:

- Standard RS422/485 communications.
- MODBUS RTU protocol – the instrument is designed to operate as a Remote Terminal Unit (RTU) slave when communicating with a master (host) system.
- 500V DC isolation from external connections to the instrument.
- Two- or four-wire communication (selected at the *MODBUS / Mode* parameter) – see page 9.
- 1200, 2400, 4800, 9600, 19200, 38400, or 115200 baud transmission rate – see page 9.
- Parity-checking (odd, even or none) – see page 9.

Warning.

- The instrument is not fitted with a switch therefore a disconnecting device such as a switch or circuit breaker conforming to local safety standards must be fitted to the final installation.
- It must be mounted in close proximity to the instrument within easy reach of the operator and must be marked clearly as the disconnection device for the instrument.
- Remove all power from supply, relay and any powered control circuits and high common mode voltages before accessing or making any connections.
- Use cable appropriate for the load currents. The terminals accept cables from 18 to 14 AWG (0.8 to 2.5mm²).
- Always route signal leads and power cables separately, preferably in earthed (grounded) metal conduit.
- It is strongly recommended that screened cable is used for signal inputs and relay connections.
- The instrument conforms to Mains Power Input Overvoltage Category 2, Pollution Degree 2 (EN601010-1). (This equipment is protected through double insulation – Class II.)
- Analog / digital inputs and outputs, transmitter power supply and DC power supply are SELV (Safety Extra Low Voltage) circuits.
- All connections to secondary circuits must have basic insulation.
- After installation, there must be no access to live parts, e.g. terminals.
- Terminals for external circuits are for use only with equipment with no accessible live parts.
- If the controller is used in a manner not specified by the Company, the protection provided by the equipment may be impaired.
- All equipment connected to the instrument's terminals must comply with local safety standards (IEC 60950, EN601010-1).

Note. Terminal screws must be tightened to a torque of 0.1 Nm (0.9 lbf/in.).

5.3 Two-wire and Four-wire Connection

MODBUS serial communications can be configured as either 2-wire or 4-wire serial links – see Fig. 5.1. The instrument must be added to the link configuration on the host system – refer to information supplied with the host system.

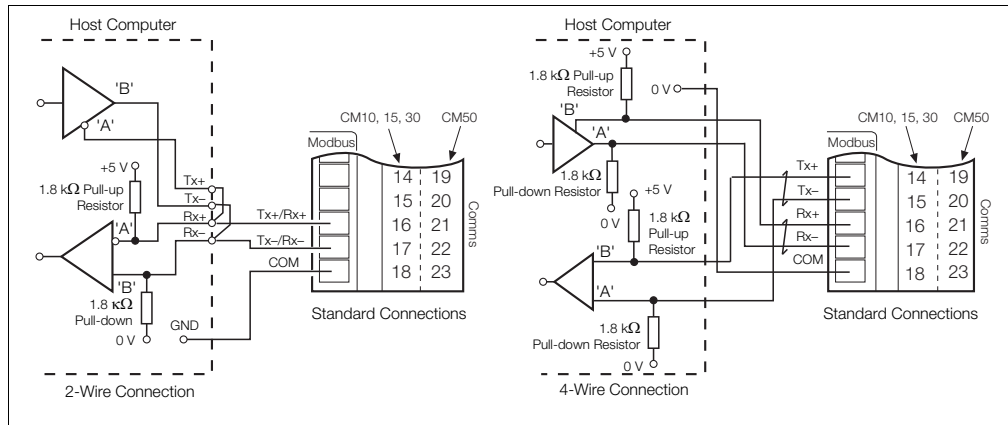

Fig. 5.1 2-Wire and 4-Wire MODBUS Serial Links

5.4 Pull-up and Pull-down Resistors

To prevent false triggering of slaves when the master (host computer) is inactive, pull-up and pull-down resistors must be fitted to the RS422/485 interface in the host computer.

Resistors are normally connected to the interface by hard-wired links or switches – refer to the manufacturer's instructions

5.5 Termination Resistor

For long transmission lines, $120\ \Omega$ termination resistors must be fitted to the last slave in the chain and the master receive – see Fig. 5.2.

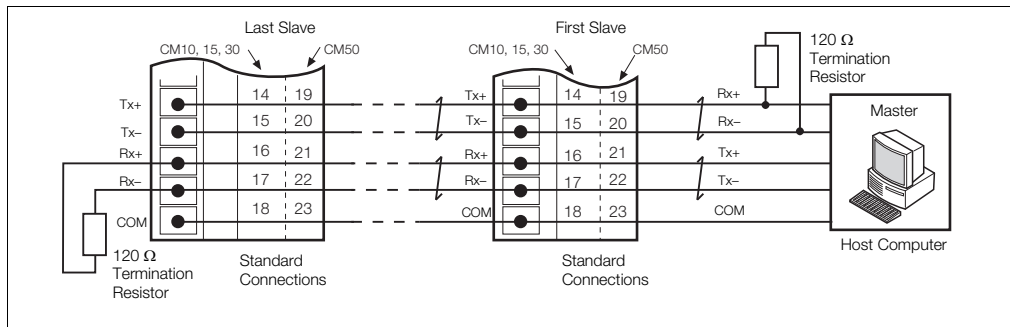

Fig. 5.2 Connecting Multiple Slaves

5.6 Serial Connections

Connections to the MODBUS serial board must be made as shown in Fig. 5.1. Connections to two- or four-wire link configurations on systems with multiple slaves must be made in parallel as shown in Fig. 5.2. When connecting cable screens, ensure that ground loops are not introduced.

The maximum serial data transmission line length for both RS422 and RS485 systems is 1200 m (3937 ft.).

The types of cable that can be used are determined by the total line length:

- Up to 6 m (19.7 ft.) – standard screened or twisted pair cable.
- Up to 300 m (984 ft.) – twin twisted pair with overall foil screen and an integral drain wire.
- Up to 1200 m (3937 ft.) – twin twisted pair with separate foil screens and integral drain wires.

6 MODBUS Tables

Note. The tables in Section 6 contain MODBUS register numbers, not PDU addresses.

6.1 Input Coils – Digital Inputs

MODBUS Coil	Title
1	Analog Input 1 Fail
2	Analog Input 2 Fail
3	Analog Input 3 Fail
8	Analog Input 4 Fail
9	Math Block 1 Fail
10	Math Block 2 Fail
11	Math Block 3 Fail
12	Math Block 4 Fail
13	Math Block 5 Fail
14	Math Block 6 Fail
15	Math Block 7 Fail
16	Math Block 8 Fail
17	Custom Linearizer 1 Fail
18	Custom Linearizer 2 Fail
19	Loop 1 Setpoint 1 Active
20	Loop 2 Setpoint 1 Active
21	Loop 1 Setpoint 2 Active

MODBUS Coil	Title
22	Loop 2 Setpoint 2 Active
23	Loop 1 Setpoint 3 Active
24	Loop 2 Setpoint 3 Active
25	Loop 1 Setpoint 4 Active
26	Loop 2 Setpoint 4 Active
27	Digital Output 1
28	Digital Output 2
29	Digital Output 3
30	Digital Output 4
31	Digital Output 5
32	Digital Output 6
33	Relay 1
34	Relay 2
35	Relay 3
40	Relay 4
41	Logic Equation 1 State
42	Logic Equation 2 State

ControlMaster CM10, CM15, CM30 and CM50

Universal process controllers and indicators, 1/8, 1/4 and 1/2 DIN

6 MODBUS Tables

MODBUS Coil	Title
43	Logic Equation 3 State
44	Logic Equation 4 State
45	Logic Equation 5 State
46	Logic Equation 6 State
47	Logic Equation 7 State
48	Logic Equation 8 State
49	Realtime Alarm 1 State
50	Realtime Alarm 2 State
51	Alarm 1 State
52	Alarm 1 Ack State
53	Alarm 2 State
54	Alarm 2 Ack State
55	Alarm 3 State
56	Alarm 3 Ack State
57	Alarm 4 State
58	Alarm 4 Ack State
59	Alarm 5 State
60	Alarm 5 Ack State
61	Alarm 6 State
62	Alarm 6 Ack State
63	Alarm 7 State
64	Alarm 7 Ack State

MODBUS Coil	Title
65	Alarm 8 State
66	Alarm 8 Ack State
67	Loop Break 1 State
68	Loop Break 2 State
69	Delay Timer 1 State
70	Delay Timer 2 State
95	Loop 1 Autotune In Progress
96	Loop 2 Autotune In Progress

6.2 Output Coils

MODBUS Coil	Title
1	Loop 1 Auto/Manual State 0 = Auto, 1 = Man
2	Loop 2 Auto/Manual State 0 = Auto, 1 = Man
3	Loop 1 Setpoint Mode 0 = Local, 1 = Remote
4	Loop 2 Setpoint Mode 0 = Local, 1 = Remote
5	Totalizer 1 Run State
6	Totalizer 2 Run State
7	Loop 1 Tracking State
8	Loop 2 Tracking State

6.3 Input Registers

6.3.1 Read-only 32 Bits

MODBUS Register	Title
4001	Totalizer 1 Batch Total
4003	Totalizer 2 Batch Total
4005	Totalizer 1 Secure Total
4007	Totalizer 2 Secure Total

6.3.2 Read-only Single Precision Float

MODBUS Register	Title
5001	Analog I/P 1 Value
5003	Analog I/P 2 Value
5005	Analog I/P 3 Value
5007	Analog I/P 4 Value
5009	Loop 1 Process Variable
5011	Loop 2 Process Variable
5013	Loop 1 Control Output
5015	Loop 2 Control Output
5029	Loop 1 Deviation

MODBUS Register	Title
5031	Loop 2 Deviation
5033	Loop 1 Feedforward Value
5035	Loop 2 Feedforward Value
5043	Loop 1 Actual Valve Position
5047	Loop 2 Actual Valve Position
5049	Loop 1 Actual Ratio
5051	Loop 2 Actual Ratio
5053	Loop 1 Remote Setpoint
5055	Loop 2 Remote Setpoint
5057	Loop 1 Split Output 1
5059	Loop 1 Split Output 2
5061	Loop 2 Split Output 1
5063	Loop 2 Split Output 2
5065	Process Variable 1 Max
5067	Process Variable 2 Max
5069	Process Variable 1 Min
5071	Process Variable 2 Min
5073	Process Variable 1 Ave
5075	Process Variable 2 Ave
5077	Volume 1

MODBUS Register	Title
5079	Volume 2
5081	Custom Linearizer 1 Value
5083	Custom Linearizer 2 Value
5085	Math Block 1 Result
5087	Math Block 2 Result
5089	Math Block 3 Result
5091	Math Block 4 Result
5093	Math Block 5 Result
5095	Math Block 6 Result
5097	Math Block 7 Result
5099	Math Block 8 Result

6.3.3 Input Registers For Bytes

MODBUS Register	Title
0001	Output 1
0002	Output 2
0003	Instrument Type
0004	Instrument IO build
0005	Instrument Functionality

6.4 Holding Registers

6.4.1 Writable 16 Bits

MODBUS Register	Title
2001	Alarm 1 Time Hysteresis
2002	Alarm 2 Time Hysteresis
2003	Alarm 3 Time Hysteresis
2004	Alarm 4 Time Hysteresis
2005	Alarm 5 Time Hysteresis
2006	Alarm 6 Time Hysteresis
2007	Alarm 7 Time Hysteresis
2008	Alarm 8 Time Hysteresis

6.4.2 Writable 32 Bits

MODBUS Register	Title
6000	Totalizer 1 Preset Value
6002	Totalizer 1 Predetermined Value
6004	Totalizer 1 Intermediate Value
6006	Totalizer 2 Preset Value
6008	Totalizer 2 Predetermined Value
6010	Totalizer 2 Intermediate Value

6.4.3 Writable Single Precision Float

MODBUS Register	Title
6590	Alarm 1 Trip
6592	Alarm 1 Hysteresis
6594	Alarm 2 Trip
6596	Alarm 2 Hysteresis
6598	Alarm 3 Trip
6600	Alarm 3 Hysteresis
6602	Alarm 4 Trip
6604	Alarm 4 Hysteresis

MODBUS Register	Title
6606	Alarm 5 Trip
6608	Alarm 5 Hysteresis
6610	Alarm 6 Trip
6612	Alarm 6 Hysteresis
6614	Alarm 7 Trip
6616	Alarm 7 Hysteresis
6618	Alarm 8 Trip
6620	Alarm 8 Hysteresis
6638	Loop 1 Local Setpoint 1
6640	Loop 1 Local Setpoint 2
6642	Loop 1 Local Setpoint 3
6644	Loop 1 Local Setpoint 4
6646	Loop 1 Remote Setpoint Ratio
6648	Loop 1 Remote Setpoint Bias
6660	Loop 2 Local Setpoint 1
6662	Loop 2 Local Setpoint 2
6664	Loop 2 Local Setpoint 3
6666	Loop 2 Local Setpoint 4
6668	Loop 2 Remote Setpoint Ratio
6670	Loop 2 Remote Setpoint Bias
6714	Loop 1 Output 1 Cycle Time
6716	Loop 1 Output 2 Cycle Time

ControlMaster CM10, CM15, CM30 and CM50

Universal process controllers and indicators, 1/8, 1/4 and 1/2 DIN

6 MODBUS Tables

MODBUS Register	Title
6718	Loop 2 Output 1 Cycle Time
6720	Loop 2 Output 2 Cycle Time
6726	Loop 1 Valve Ratio
6728	Loop 1 Valve Bias
6730	Loop 1 Valve Deadband
6732	Loop 2 Valve Ratio
6734	Loop 2 Valve Bias
6736	Loop 2 Valve Deadband
6778	Loop 1 Proportional Band 1
6780	Loop 1 Integral Time 1
6782	Loop 1 Derivative Time 1
6784	Loop 1 Proportional Band 2
6786	Loop 1 Integral Time 2
6788	Loop 1 Derivative Time 2
6790	Loop 1 Proportional Band 3
6792	Loop 1 Integral Time 3

MODBUS Register	Title
6794	Loop 1 Derivative Time 3
6796	Loop 1 Manual Reset
6802	Loop 1 Feedforward Gain
6816	Loop 2 Proportional Band 1
6818	Loop 2 Integral Time 1
6820	Loop 2 Derivative Time 1
6822	Loop 2 Proportional Band 2
6824	Loop 2 Integral Time 2
6826	Loop 2 Derivative Time 2
6828	Loop 2 Proportional Band 3
6830	Loop 2 Integral Time 3
6832	Loop 2 Derivative Time 3
6834	Loop 2 Manual Reset
7146	Loop 1 Control Output
7148	Loop 2 Control Output

Note. For further MODBUS registers contact your local ABB representative.

7 Ethernet Connections

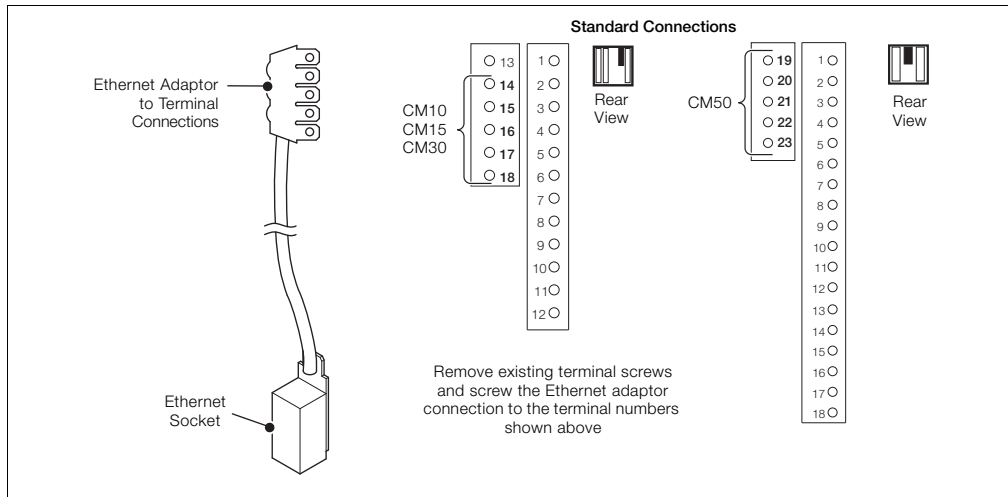

Fig. 7.1 Ethernet Connections

8 Specification

Communications

Note. Only 1 optional communications board can be fitted per controller.

MODBUS¹ RTU (optional)

Baud rate	Up to 115 k Baud
Isolation	Galvanically isolated from the rest of the circuitry, 500 V DC for 1 minute

Ethernet (optional)

Type	10Base T
Connector	RJ45
Protocols	TCP/IP HTTP MODBUS TCP (slave)
Web server	Built-in, enables remote monitoring using standard web browsers
Email	Can be configured to be sent on the occurrence of a specified event Up to 3 recipients Up to 4 trigger sources with configurable tag

1. MODBUS is a registered trademark of the MODBUS-IDA organization

Notes

Customer Support

We provide a comprehensive after sales service via a Worldwide Service Organization. Contact one of the following offices for details on your nearest Service and Repair Centre.

UK

ABB Limited

Tel: +44 (0)1480 475321

Fax: +44 (0)1480 217948

USA

ABB Inc.

Tel: +1 215 674 6000

Fax: +1 215 674 7183

Client Warranty

Prior to installation, the equipment referred to in this manual must be stored in a clean, dry environment, in accordance with the Company's published specification.

Periodic checks must be made on the equipment's condition. In the event of a failure under warranty, the following documentation must be provided as substantiation:

- 1 A listing evidencing process operation and alarm logs at time of failure.
- 2 Copies of all storage, installation, operating and maintenance records relating to the alleged faulty unit.

Contact us

ABB Limited

Process Automation

Howard Road

St. Neots

Cambridgeshire PE19 8EU

UK

Tel: +44 (0)1480 475321

Fax: +44 (0)1480 217948

ABB Inc.

Process Automation

125 E. County Line Road

Warminster

PA 18974

USA

Tel: +1 215 674 6000

Fax: +1 215 674 7183

www.abb.com

Note

We reserve the right to make technical changes or modify the contents of this document without prior notice. With regard to purchase orders, the agreed particulars shall prevail. ABB does not accept any responsibility whatsoever for potential errors or possible lack of information in this document.

We reserve all rights in this document and in the subject matter and illustrations contained therein. Any reproduction, disclosure to third parties or utilization of its contents in whole or in parts – is forbidden without prior written consent of ABB.

Copyright© 2013 ABB

All rights reserved