



TIMER TM-619 / TM-6331

PROGRAMMABLE TIME INTERRUPTERS - OPERATING MANUAL V1.0x

1. OPERATING FEATURE

The Programmable Time Interrupters **NOVUS**, available on **TM-619** and **TM-6331** models, are electronic devices that permit switching electrical loads (alarm, appliances, etc.) at programmed time intervals with good accuracy.

Their microprocessor let you create at most **eight (8)** ON/OFF programs, which can switch electrical loads at specific moments throughout the week.

They have a battery, that give to the timer the feature of hold the programs and run the internal clock for many weeks, even in case of power outage.

The output of the **TM-619** is composed of a relay with the terminals NA, C and NF (SPDT).

The output of the **TM-6331** is composed of a relay with the terminals NA and C (SPST).

In both cases, the relays will not be energized during the power failure, leaving the outputs inoperative.

2. SPECIFICATIONS

2.1 TM-619 MODEL

- POWER: 12 Vdc, 24 Vdc, 110 Vac or 240 Vac, 50/60 Hz (see identification tag);
- Switching low interval: 1 minute;
- OUTPUT: Relay 16 A / 250 Vac, resistive; 8 A / 250 Vac, inductive;
- Operational temperature: 0 to 60 °C;
- Storage temperature: -10 to 75 °C;
- Light indicator for output on (when powered);
- Proper for be fixed with screw.

2.2 TM-6331 MODEL

- POWER: 120 Vac or 240 Vac (switchable), 50/60 Hz; (see identification tag);
- Switching low interval: 1 minute;
- OUTPUT: Relay 16 A / 250 Vac, resistive; 8 A / 250 Vac, inductive;
- Operational temperature: 0 to 60 °C;
- Storage temperature: -10 to 75 °C;
- Light indicator for output on (when powered);
- Proper for be fixed with screw.

3. OPERATION MODES

There are three operation modes: **ON**, **AUTO** and **OFF**, select through the **MANUAL** key. When the **MANUAL** key is pressed, observe that the indicator (line) on the screen move upon the words ON/AUTO/OFF:

- **MODO ON:** When the indicator is upon ON the output turn on immediately and keep this status while in ON mode.
- **MODO OFF:** When the indicator is upon OFF the output turn off immediately and keep this status while in OFF mode.
- **MODO AUTO:** When the indicator is upon AUTO the output turn on and turn off based on the programs.

When the timer isn't powered, it turns off the output permanently.

4. UPDATING DAY/HOUR/MINUTE

Keep pressed the **CLOCK** key, then press:

- **DAY:** To update the indicated day of week;
- **HOUR:** To update the indicated hour;
- **MIN:** To update the indicated minutes.

The terms **MO**, **TU**, **WE**, **TH**, **FR**, **SA** and **SU** correspond to the weekdays:

| | |
|-----------|-----------|
| MO | Monday |
| TU | Tuesday |
| WE | Wednesday |
| TH | Thursday |
| FR | Friday |
| SA | Saturday |
| SU | Sunday |

Table 1 - Indicators

5. DETERMINING THE ON/OFF CYCLES

Press the **TIMER** key to access and configure the ON/OFF programs. The program number, which is at editing, is showed on the left side of the screen.

The first edit refers to the program 1 and determine the moment to turn on the output. The message **ON** will be displayed on the program number

- Press **DAY** to determine the day which the output should turn on. Observe that the indication of the weekdays is changed at each time that **DAY** key is pressed:
 - **Mo, Tu, We, Th, Fr, Sa, Su** (everyday)
 - **Mo** (any day of the week);
 - **Tu** (Tuesday);
 - **We** (Wednesday);
 - **Th** (Thursday);
 - **Fr** (Friday);
 - **Sa** (Saturday);
 - **Su** (Sunday);
 - **Mo, Tu, We, Th, Fr** (business days);
 - **Sa, Su** (weekend);
 - **Mo, Tu, We, Th, Fr, Sa** (business days more Saturday);
 - **Mo, Tu, We** (Monday, Tuesday and Wednesday);
 - **Th, Fr, Sa** (Thursday, Friday and Saturday);
 - **Mo, We, Fr** (Monday, Wednesday and Friday);
 - **Tu, Th, Sa** (Tuesday, Thursday and Saturday).
- Press the **HOUR** key to determine the hour on the chosen days, in which the output turns on.
- Press the **MIN** key to determine the minutes.

The second edit is used to determine the OFF time of the output in program 1 and can be performed by pressing the **TIMER** key again. The message OFF will be displayed on the program number.

The programming of day, hour and minute is made identical of the programming of turn ON, showed before:

- Press **DAY** key to determine the days when the output is turned off.
- Press the **HOUR** key to determine the hour when the output turns off.
- Press the **MIN** key to determine the minutes.

Press the **TIMER** key again and the program number displayed will change to 2, indicating that the following adjusts refer to program 2. Configure the program 2 as the instruction above. Then access and determine the other programs, in a total eight programs.

These programs will be used by the timer when the operation mode selected is AUTO. In the time programmed to ON, the output turns on. In the time programmed to OFF, the output turns off.

In the case of overlapping programs, the output will act like the example showed at the **Fig. 01**.

When it's already on, and came a time when some program turn off, the output turn off. When came a time in some program when turn on, the output doesn't change.

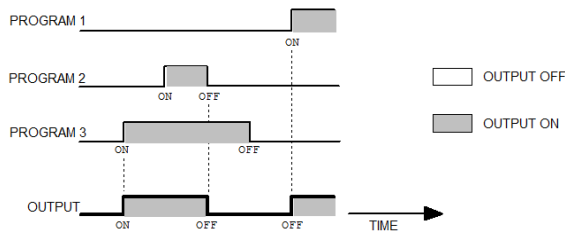

Fig. 01 - Output's Behavior with overlapping programs

6. IDENTIFICATION

6.1 TM-619 MODEL

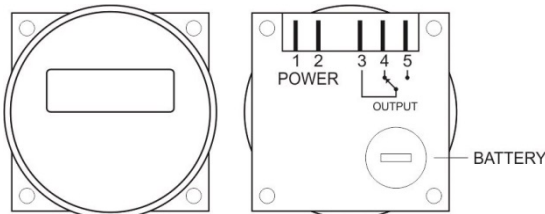

Fig. 02 - The front and the back sight of Timer TM-619

6.2 TM-6331 MODEL

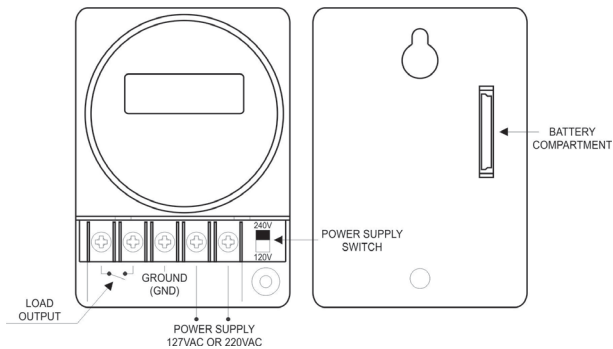

Fig. 03 - The front and the back sight of Timer TM-6331

6.3 SCREEN ELEMENTS

The screen elements of the **TM-619** and the **TM-6331** are the same.

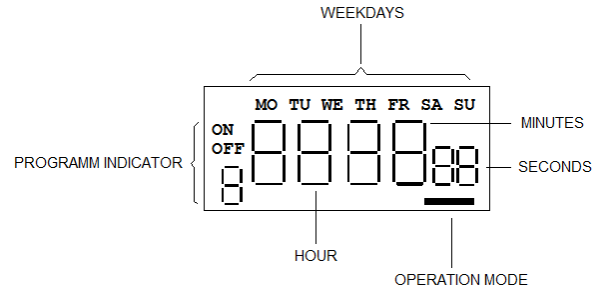

Fig. 04 - Identification of screen elements

7. RESET

When the **RESET** key is pressed the interrupter clock is reset and all the programs are deleted.

8. BATTERY

The program used in **TM-619** and **TM-6331** models is stored in a memory protected by battery, when this battery's charge is reduced a message is showed at the screen indicating that the battery should be replaced.

Use battery CR-2032.

Estimated range: 2 years.

8.1 TM-619 MODEL

Observe the following figures to replace the **TM-619's** battery:

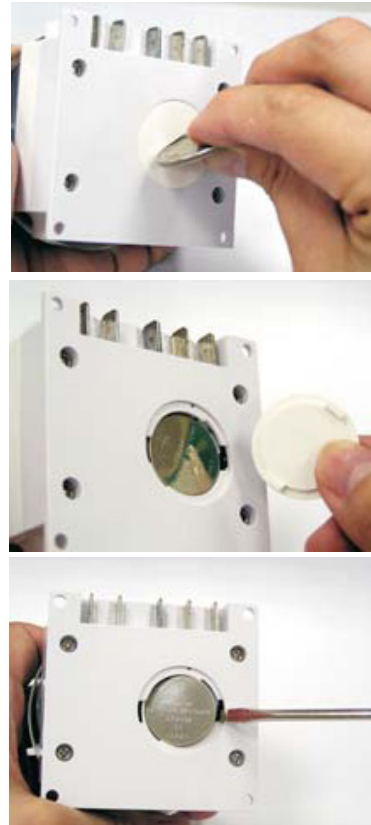

Fig. 05 - Instruction to replace the TM-619's battery

8.2 TM-6331 MODEL

Observe the following figures to replace the TM-6331's battery:



Fig. 06 - Instruction to replace the TM-6331's battery

9. TIMER CONNECTION MODEL TM-6331

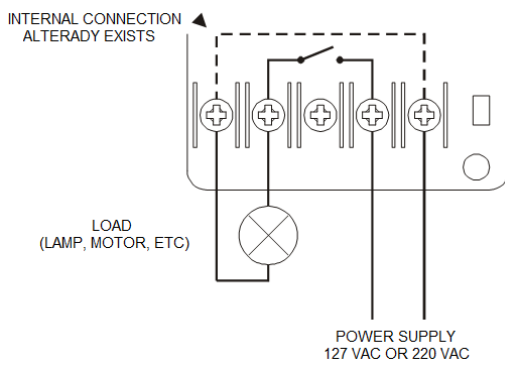

Fig. 07 - TM-6331: Timer Connection



Relay output is not isolated from the power supply.

The output terminals have common points with the power terminals.

10. WARRANTY

The warranty conditions are found in our website www.novusautomation.com/warranty.

Product marketed by NOVUS.