

FEATURES

The Solid State Relays (SSR) are electronic devices used for switching resistive or inductive AC loads with many advantages over the conventional relays.

Increased lifetime, due to the fact that there are no moving parts, and thus, no mechanical wear. Zero cross switching, which implies lower electrical noise. Silent operation. Control INPUT signal optically isolated from the OUTPUT. Internal snubber provided.

OPERATION

A control voltage applied to the device INPUT turns the SSR ON, energizing the load. The conduction effectively occurs at the next zero crossing of the mains voltage. When the INPUT signal is removed, the SSR turns OFF when the load reaches a current equal to zero. This means that the load switching may be delayed by 1/2 of mains period (or 8.3 ms for the 60 Hz mains).

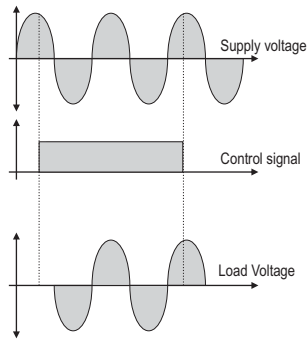

Turning the output ON and OFF only on the mains voltage zero crossing brings important performance advantages to the system: practically no EMI is generated during the load switching and the SSR is submitted to less severe switching conditions. On the other hand, the SSR is suitable to AC loads only (it cannot be used to switch DC loads).

The SSR control signal is indicated by a LED on the SSR body.

ELECTRICAL CONNECTIONS

The two connections needed for the installation of the SSR are the command signal and the load circuit. The load circuit must be protected by an ultra-fast fuse with a rate that matches the SSR nominal current specification. The SSR terminals must be firmly screwed and the wire gauge compatible with.

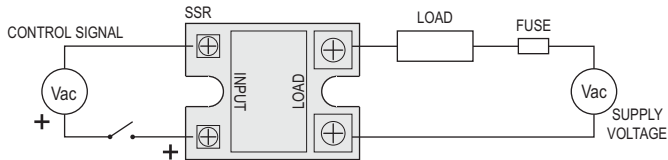

Fig 1 - Electrical connections

SPECIFICATIONS

Parameter	Unit	Model	
		SSR-4840AC	SSR-4880AC
Load current (I _L)	A rms	40	80
Load voltage	V rms	40 to 530	40 to 530
Turn-on voltage (V _{SSR})	V rms	1.1 to 1.5	1.6 to 1.8
Leakage current	mA rms	< 8	< 8
Frequency	Hz	47 to 63	47 to 63
dv/dt	V/μs	300	300
Control voltage	V rms	90 to 280	90 to 280
Control current	mAcc	5 to 10	5 to 10
Switching time	ms	< 10	< 10
Control method		Zero cross trigger (resistive load) Instantaneous (inductive load)	Zero cross trigger (resistive load) Instantaneous (inductive load)
Electrical insulation	V rms	4000	2000
Operating temperature	°C	-40 to 80	-40 to 80

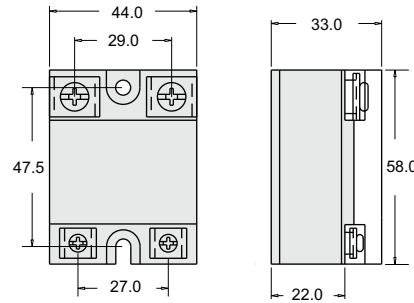

Fig 2 - Dimensions

HEAT DISSIPATION

The SSR generates heat during its conduction. This heat must be dissipated to avoid SSR fail due to over-heat. The nominal SSR load specification assumes the use of a suitable heat sink. Without a heat sink the allowed load current is substantially reduced. The user may calculate the needed heat sink or make use of a heat sink suggested by Novus.

$$R_{thsa} = \frac{75^{\circ}\text{C} - T_{amb}}{I_L \times V_{SSR}}$$

Where:

R_{thsa} = Thermal resistance heat sink to ambient

T_{amb} = Maximum ambient temperature

I_L = Load current

V_{SSR} = Voltage drop when the SSR is ON.

75°C is the maximum temperature allowed for the SSR.

For better heat transfer, a thermal conducting paste must be used between the SSR and the heat sink. The SSR along with its heat sink must be mounted in a vertical position such as to allow for air flow and thus a good heat exchange.

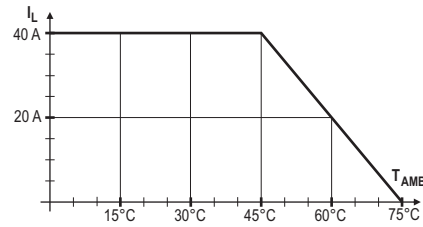

Fig. 3 - SSR2540/4840 + sink ND40-100 mm

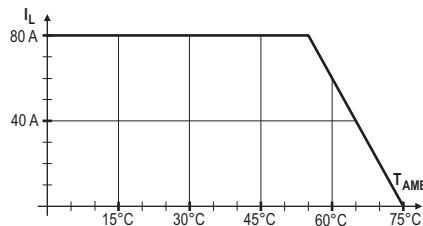

Fig. 4 - SSR4880 + sink NDP3-120 mm + Fun 3 m/s

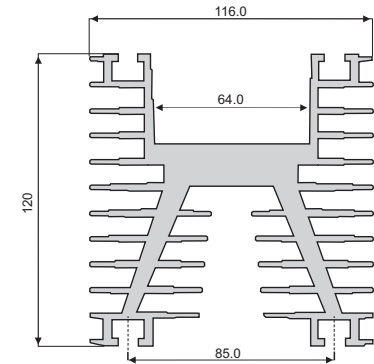

Fig. 5 - Sink ND40 (to 100 mm: R_{thsa} = 0.65 °C / W)

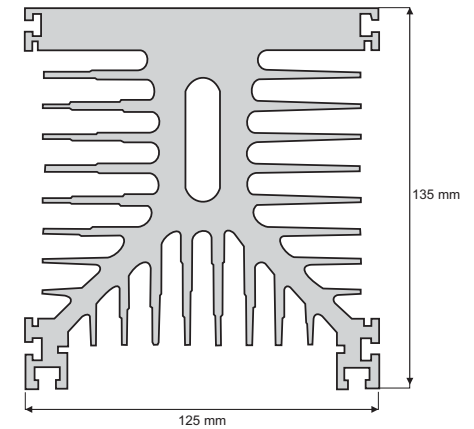

Fig. 6 - Sink NDP3 (to 120 mm: R_{thsa} = 0.52 °C / W)

Product sold by NOVUS Automation.