

FB420 Shaft Speed Sensor

Description:

Electro-Sensor's FB420 is a shaft speed sensor that provides a 4-20 mA signal that is directly proportional to the rotational speed of a monitored shaft.

Since both the 4 mA and 20 mA calibration points are programmable the user can also if desired operate the FB420 with the 4 mA offset from 0 RPM.

The FB420 has a 4 digit LCD display that is used for calibration and for trouble-shooting. The LCD is capable of displaying from '0.000' to '9999.' RPM, or from '04.00' to '20.00' mA.

The FB420 has one relay that can be programmed for either failsafe over/underspeed alarm.



Figure 2: FB420 Front-View

FB420 Installation:

The FB420 needs a rotating target installed on the application's drive-shaft, etc. A typical rotating target is a 255 Pulser Disc (with or without an optional EZ-Mount bracket), or an optional custom-made Pulser Wrap. (See Figure's 4a, 4b, and 4c).

Electrical connections

The FB420's electrical connections are as follows:

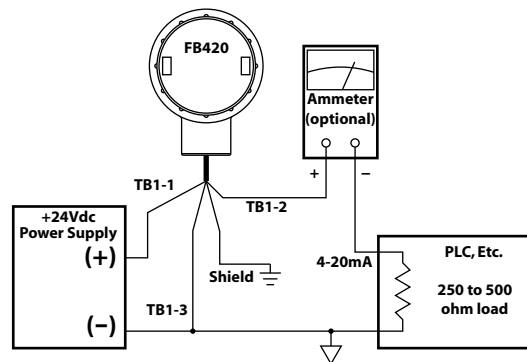

Figure 3:

- Connect any shield wire to the earth ground (if used).
- Connect TB1-1 to the power-supply (+24 Vdc) terminal.
- Connect TB1-2 to a resistive load of 250 Ω to 500 Ω , (usually this load is internal to a PLC, etc.).
- Connect TB1-3 to the power-supply (-) terminal.

Note: TB1-2 is the 4-20 mA DC output line.

The other side of the 250 Ω to 500 Ω load must be connected to the power-supply (-) terminal.

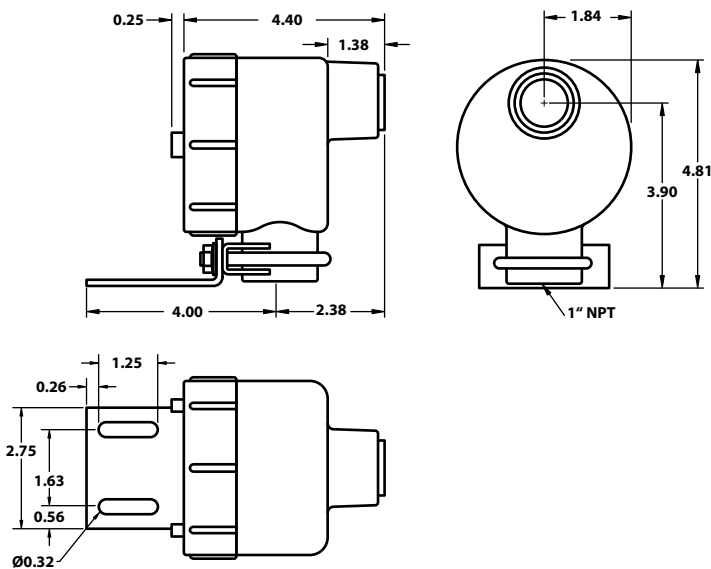

Figure 1: FB420 Dimensions w/Bracket and U-Clamp

Pulser Disc:

The end of the shaft to be monitored must be center drilled to a depth of 1/2–inch with a #21 drill and tapped for a 10-32 UNF. After applying Loctite™ or a similar adhesive on the threads to keep the pulser disc tight, the pulser disc should be attached, decal side out with the supplied 10-32UNF machine screw and lock washer. Dimension (A) is 1/16 inch to 1/4 inch. The center-line of the magnets (B) must align with the center of the sensing head as the Pulser Disc rotates.

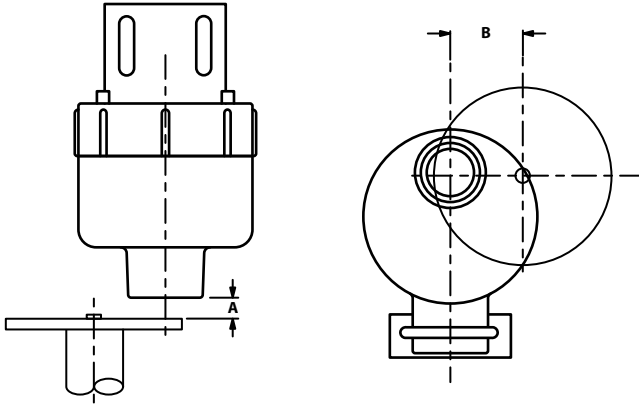

Figure 4a: FB420 with 255 Pulser Disc

Pulser Wrap (optional):

Pulser wraps are custom manufactured to fit the shaft they will be mounted on. When the wrap is shipped, four Allen-head cap screws hold the two halves of the wrap together. These screws must be removed so the wrap is in two halves. Place the halves around the shaft, reinsert the screws and torque them to 8 foot-pounds. Dimension (A) is 1/16 inch to 1/4 inch. The center-line of the magnets (B) must align with the center of the sensing head as the Pulser Wrap rotates.

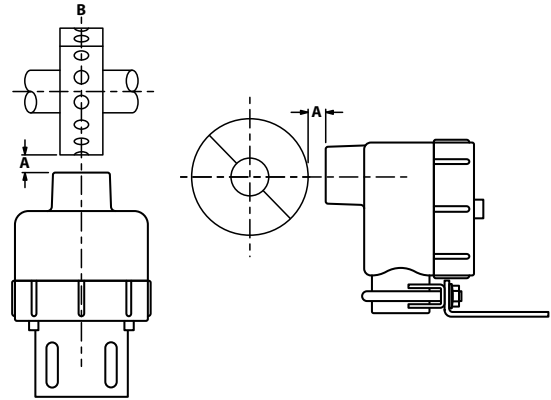

Figure 4c: FB420 with Pulser Wrap

EZ-Mount Bracket with Pulser Disc (Optional)

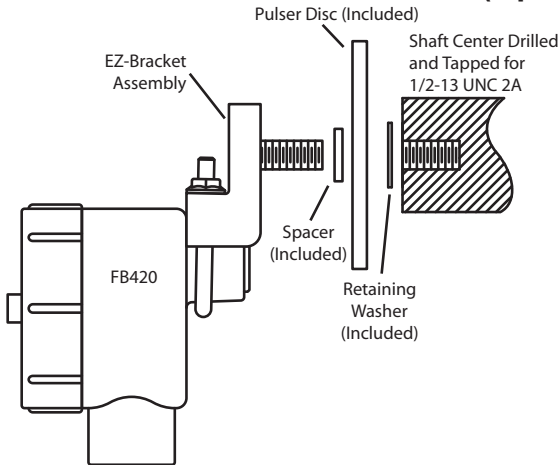

Figure 4b: FB420 with EZ-Mount Bracket

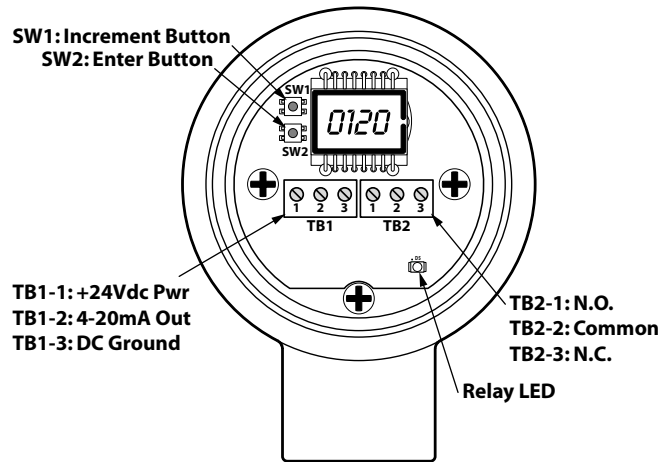

Figure 5: FB420 Rear-View (Cover Removed). Showing the power/signal terminal TB1, the relay terminal TB2, the push-buttons SW1 and SW2, and the relay LED

List of Variables

VAR	Mnemonic	Description	Range	Decimal Place	Default	User's Value
01	Pulses Per Rev	Pulses per revolution of target	0001. to 9999.	Fixed at XXXX.	0008	
02	Min. RPM	RPM value corresponding to 4 mA	0000 to "97.5% of Var03"	dec pt tied to Var03	0000	
03	Max. RPM	RPM value corresponding to 20mA	0.000 to 9999.	User selectable	200	
04	Relay Function Select	Unused, Over-speed, Under-speed	0000. to 0002.	Fixed at XXXX.	0000	
05	Relay Set-point RPM	Relay alarm trip point in RPM	0000 to 9999	dec pt tied to Var03	0000	
06	Relay Set-point Delay	Alarm event 'wait' time in seconds	0000. to 0030.	Fixed at XXXX.	0000	

The FB420 has two modes of operation:

Normal Mode:

This mode indicates the target's speed via the 4-20 mA output signal. The LCD display shows the shaft speed in RPMs, or as a mA value (04.00 to 20.00 mA). The relay energizes or de-energizes as per the RPM set-point value. 'Normal Mode' is indicated by the absence of the "VAR" icon in the lower left corner of the display.

Toggling the view in Normal Mode:

Press the SW1 button to toggle the LCD between displaying the speed value in 'RPM' or in 'mA'.

- When displaying 'RPM' values the LCD does not show the "RATE" icon in the lower right corner of the display.
- When displaying 'mA' values the LCD does show the "RATE" icon in the lower right corner.

Program Mode:

This mode allows the user to change the variables. The LCD display shows the present active variable or its value. 'Program Mode' is indicated by the presence of the "VAR" icon in the lower left corner of the display. Programming is accomplished by utilizing the two pushbuttons: the Increment button (SW1), and the Enter button (SW2). (See Figure 5 showing location of SW1 and SW2).

To enter the Program Mode:

- Press the enter button (SW2). The "VAR" icon will display and the 4 digits will show "Pr01".
- Press the Increment button (SW1) repeatedly until you get to the variable you want to change.
Note: There are 6 user variables, Pr01 through Pr06.
- Press the Enter button (SW2) to access that variable.
- While in that variable you must use the Increment button (SW1) to change the active digit (flashing digit), then the Enter button (SW2) to save and work your way through all the digits and the decimal place.
- When you are done with that variable you will see "Pr0X, the 'X' being the variable you just programmed.
- To step to the next variable use the Increment button (SW1). To exit the program mode repeatedly press the Increment button (SW1) until the "VAR" icon disappears. The FB420 is now back in the normal mode.

Resetting the FB420's variables to factory-defaults:

- Remove the +24 VDC power.
- Simultaneously press and hold the SW1 and SW2 buttons.
- Apply the +24 VDC power.
- When the LCD shows "rESE", release the buttons.
- The user variables are then automatically reset to the factory-default values.

LCD Display Messages	meanings, effects, how to clear them if necessary (troubleshooting)
Err0	<ul style="list-style-type: none"> • Var02_MIN_RPM is greater than 97.5% of Var03_MAX_RPM. • The output signal is 12 mA, and the relay is in the de-energized 'alarm' state until Err0 is cleared. • Verify Var02_MIN_RPM and Var03_MAX_RPM, and modify if needed.
Err1	<ul style="list-style-type: none"> • The FB420's programmed MaxHz is above the maximum allowed 9999 Hz: (MaxHz > 9999). MaxHz = Var01_PPR * Var03_MAX_RPM / 60. • The output signal is 12 mA, and the relay is in the de-energized 'alarm' state until Err1 is cleared. • Verify Var01_PPR and Var03_MAX_RPM, and modify if needed.
Err2	<ul style="list-style-type: none"> • The FB420's programmed MaxHz is below the minimum allowed 0.5 Hz: (MaxHz < 0.5). • The output signal is 12 mA, and the relay is in the de-energized 'alarm' state until Err2 is cleared. • Verify Var01_PPR and Var03_MAX_RPM, and modify if needed.
Err3	<ul style="list-style-type: none"> • The system is running at a speed above the FB420's absolute maximum rating of 9999 Hz (i.e., above 9999 Hz + a safety margin). • The output signal is 20 mA during an Err3. • Verify Var01_PPR and Var03_MAX_RPM, and modify if needed. Or reduce the speed. Or use a rotating target with a lower PPR.
Err4	<ul style="list-style-type: none"> • The system is running at a speed above the FB420's internal range as set by the MaxHz value. (Note: The FB420 automatically chooses the best range in which to operate, as per the MaxHz value. The ranges are: 0 to 9.999 Hz, 0 to 99.99 Hz, 0 to 999.9 Hz, or 0 to 9999 Hz). • The output signal is 20 mA during an Err4. • Verify Var01_PPR and Var03_MAX_RPM, and modify if needed. Or reduce the speed. Or use a rotating target with a lower PPR.
Flashing "9999"	<ul style="list-style-type: none"> • The FB420 is displaying the speed in 'RPM', but the speed is above the LCD's '9999' capability. • The output signal is 20 mA during this warning.
Flashing "04.00"	<ul style="list-style-type: none"> • The FB420 is displaying the speed in 'mA', but the speed is below the Var02_MIN_RPM. • The output signal is 4 mA during this warning.
Flashing "20.00"	<ul style="list-style-type: none"> • The FB420 is displaying the speed in 'mA', but the speed is above the Var03_MAX_RPM. • The output signal is 20 mA during this warning.
"St0P"	<ul style="list-style-type: none"> • The monitored shaft is stopped. • Or, the FB420 is gapped too far from the Disc or the Wrap. • Or, the Disc or Wrap is damaged. • Or, the FB420 is damaged. • The output signal is 4 mA during this message.



FB420 General Specifications:

Input Power	Input Current	Fuse Type
REQUIRES ISOLATED +24 VDC ±10%	55mA (when 20mA signal and relay energized)	REQUIRES External Fuse 0.100A slo-blo

Input Signal	Parameters
Type	Magnetic alternating
Range of Operation	Overall = 0.1 Hz to 9999 Hz. (With 8 PPR = 0.75 RPM to 9999* RPM. *Note: the LCD can only display up to 9999).
Gap distance	1/16" to 1/4"

Analog Output Signal	Parameters
Type	4-20 mA, with programmable end-points: (4 mA @ user's Min RPM) (20 mA @ user's Max RPM)
Accuracy	±0.7%
4-20 mA Resolution	Depends on calibration, but can be a best of 0.001 mA per increment
Required impedance	4-20 mA output needs a 250 to 500 Ω load
Max signal distance	Using a 3-conductor cable with 17.5 Ω /1000 ft. per conductor, the maximum length of cable usable with the FB420 is: <ul style="list-style-type: none"> • 3800 ft. when not using the relay • 2300 ft. when using the relay

Relay Output Data	Parameters
Number Available	1 SPDT Form C
Relay Contact Rating	5 Amp @ 30 Vdc 5 Amp @ 250 Vac
Relay Functions	Fail-safe 'alarm' state is relay de-energized: <ul style="list-style-type: none"> • Unused, • Fail-safe Over-speed, • Fail-safe Under-speed,

Physical/Environment	Parameters
 Class I, Div 1, Group C, D Class II Groups E, F, G UL File: E249019 	
Additional Rating	NEMA 4X, Gasket Provided
Operating Temp	-40°C to +65°C (-40°F to +149°F)
Storage Temperature	-40°C to +80°C (-40°F to +176°F)
Humidity	0% to 90% non-condensing

Definitions:

Pulse Per Rev (Var01)

The Pulse Per Rev value, or PPR, is the number of pulses generated per revolution of the magnetic target mounted on the rotating shaft. Note: See LCD messages "Err1" through "Err4" regarding Var01.

MIN RPM value (Var02)

The MIN_RPM value sets the speed corresponding to an output of 4 mA. The MIN_RPM value can be anywhere from 0000** RPM up to 097.5% of Var03 MAX_RPM, with the decimal point locked in the same position as Var03.

**Note: If Var02 = 0000 RPM, then the corresponding 4 mA speed is either 0.1 Hz or 0.5 Hz, as per the 'MaxHz' value.

Note: See LCD message "Err0" regarding Var02.

MAX RPM value (Var03)

The MAX_RPM value sets the speed corresponding to 20 mA output. Note: See LCD messages "Err0" through "Err4" regarding Var03.

Relay Function Selection (Var04)

The Relay Function Selection value determines how the relay responds. The choices are:

- Unused (0000),
- Fail-safe Over-speed (0001),
- Fail-safe Under-speed (0002).

Relay RPM Set-point value (Var05)

The Relay RPM Set-point value programs the trip point for the relay. The relay drops when the RPM set-point value is passed (i.e., goes into the de-energized 'alarm' state, with the green relay LED = OFF).

Note: There is however a 6.25% hysteresis for pulling-in the relay (i.e., returning to the energized 'non-alarm' state, with the green relay LED = ON).

- For under-speed operation it means the shaft speed must be 6.25% faster than the set-point to pull-in.
- For over-speed it means the shaft speed must be 6.25% slower than the set-point to pull-in.

Note: See Figure 5 showing the location of the green relay LED.

Relay Set Point Delay (Var06)

The Relay Set Point Delay determines how many seconds an 'alarm' event condition must exist before de-energizing the relay.

Loss of feedback

If feedback pulses are lost when running, the FB420 waits an amount of time equal to "(1/real-time-frequency) + another 12.5% of that" before it begins to cascade the 4-20 mA output down towards 4 mA, and the LCD down towards "St0P".

Software identification

During power-up the LCD first shows "8.8.8.8." along with the icons "VAR" and "RATE" (as a test). Next, the LCD shows the software ID in the "X.X.X.X." format, where the first two digits are the version number, and the last two digits are the revision number.

Resolution (of the 4-20 mA signal, and LCD's RPM value)

The 4-20 mA signal: For best resolution of the 4-20 mA output, the FB420 automatically selects from one of four internal operating ranges as per the programmed 'MaxHz' value. The ranges are:

- If 'MaxHz' is between 0.5 Hz and 9.999 Hz, then the internal operating range = 0.1 Hz to 9.999 Hz.
- If 'MaxHz' is between 0.5 Hz and 99.99 Hz, then the internal operating range = 0.1 Hz to 99.99 Hz.
- If 'MaxHz' is between 0.5 Hz and 999.9 Hz, then the internal operating range = 0.5 Hz to 999.9 Hz.
- If 'MaxHz' is between 0.5 Hz and 9999. Hz, then the internal operating range = 0.5 Hz to 9999. Hz.

This allows the FB420 to use the smallest frequency range to cover the application, thus improving resolution. Then depending on the programmed MIN_RPM and MAX_RPM values, the resulting 4-20 mA resolution can be as tight as 0.001 mA per increment.

The LCD's RPM value: The Var03_MAX_RPM's decimal point position affects the resolution of the LCD displayed RPM value. For best resolution of the displayed RPM value, program Var03 with the greatest number of decimal places possible (XXXX. to X.XXX).

Note: Var03 dectpt position has no effect on the 4-20 mA resolution.

Note: Specifications subject to change without notice.

Copyright © 2009, Electro-Sensors, Inc.

Free Catalog and Application Assistance
1.800.328.6170

Website: www.electro-sensors.com

990-003400 Revision C

