

SLIDE WIRE TRANSMITTERS

SEM203 W

- SUITABLE FOR VARIABLE RESISTANCE SENSORS (1 to 100) KΩ
- UNIQUE PUSH BUTTON CONFIGURATION WITHOUT PC
- CONFIGURABLE IN SECONDS
- <50 mS RESPONSE TIME
- 2 WIRE (4 to 20) mA LOOP POWERED

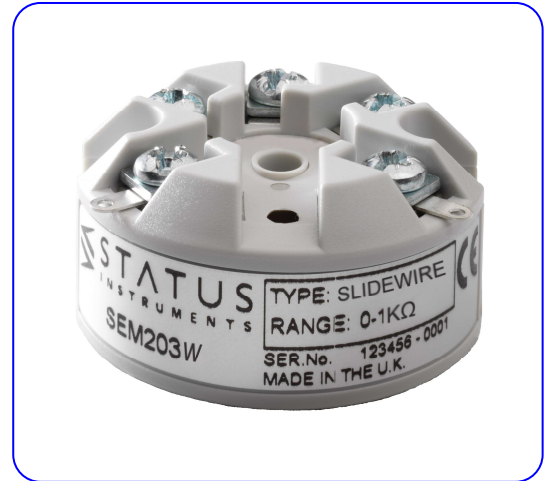

INTRODUCTION

The SEM203/W is an in head transmitter that accepts slide wire sensors and converts sensor output over a configured range to a standard industrial (4 to 20) mA transmission signal.

A simple push button operation allows the user to select the desired transmitter range manually, by setting the slide wire position and pressing button to store at both 4 mA and 20 mA points.

The SEM203W in head transmitter incorporates the latest digital technology to ensure accurate drift free performance.

PUSH BUTTON CONFIGURATION

A single push button and LED indicator allows the user configure transmitter range against a manually set input condition. A red LED is included to help guide the user. The LED also operates as a sensor error indicator.

SPECIFICATIONS @ 20 °C

INPUT

Sensor Type	Slide Wire
Sensor Range	1 kΩ to 100 KΩ pot
Sensor Connection	Screw terminal
Minimum span	5 %
Measurement Accuracy	± 0.25 %
Thermal Drift	± 0.01 % / °C
Excitation current	200 uA Max with 1 KΩ slide wire
Measuring resolution	> 9 Bits (> 512 counts)

OUTPUT

Output Type	2 wire (4 to 20) mA current loop
Output range	(4.0 to 20.0) mA
Output Connection	Screw Terminal
Maximum output	20.5 mA
Minimum output	<3.9 mA
Accuracy	(mA output /1000) or 10 uA (Which ever is the greater)
Loop Voltage effect	0.2 uA / V
Thermal drift	± 2 uA / °C
Maximum load Ohms	(Vs - 10) / 0.021 (Example: 666 Ohms @ 24 V)

GENERAL SPECIFICATION

Response time	< 50 ms to reach 70% final value
Start up time	2 seconds (1 out < 4 mA during start up)
Warm-up time	1 minute to full accuracy
Power Supply	(10 to 30) Volts dc
Open circuit detect	not defined

ENVIRONMENTAL

Ambient operating range	(-40 to +85) °C
Ambient storage temperature	(-50 to +90) °C
Ambient humidity range	(10 to 90) % RH non condensing

PHYSICAL

Dimensions	43 mm diameter; 21 mm height
Weight	31 g (encapsulated)

APPROVALS

EMC - BS EN 61326 -	Electrical equipment for measurement control and laboratory use.
ANNEX A	Immunity test requirements for equipment intended for use in industrial locations
ANNEX F	Test configurations, operational conditions and performance criteria for transducers with integrated or remote signal conditioning.
IEC 61000-4-2	Electrostatic discharge
IEC 61000-4-3	EM Field
IEC 61000-4-4	Transient Burst (output)
IEC 61000-4-5	Surge (output)

Note - Sensor input wires to be less than 3 metres to comply.

SLIDE WIRE TRANSMITTER

MECHANICAL

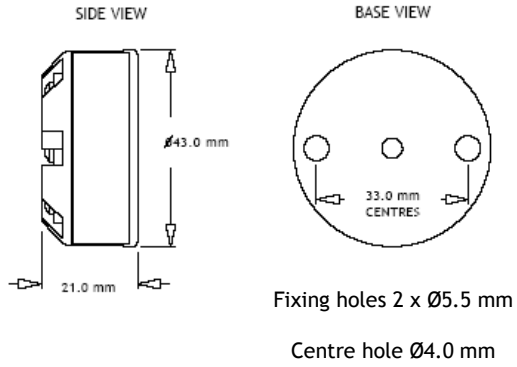

WIRING CONNECTIONS

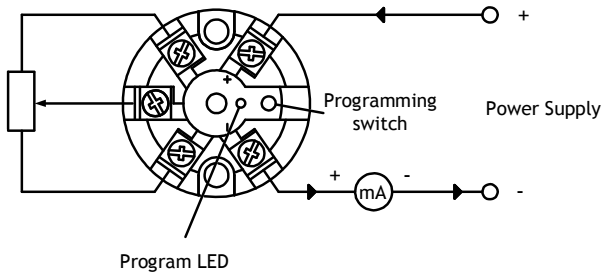

ORDER CODE

SERIES

SEM203W