



Superior • Systems • Solutions

## UDS 1000 Reverse Rotation Detector

- Easy installation and calibration
- Rugged system is dirt, dust, and grease proof
- UL and CSA approved to applicable standards
- Explosionproof cast aluminum housing
- Shaft reversal de-energizes relay
- Unit automatically resets when reverse motion stops
- 5-Year Limited warranty on speed switches, sensors and ratemeters.\*

\* Contact factory for more information.



## Product Information

### Description

The UDS1000 is a complete system designed to detect shaft reversal. During operation, the UDS1000 energizes its relay when the monitored shaft is either at rest or turning in the desired direction of rotation. When the monitored shaft turns in reverse, or the "wrong direction", the relay de-energizes. The relay contacts can be used for equipment shutdown, to prevent start-up, or to provide an alarm. The UDS1000 is ideal for detecting reverse rotation on Pump Shafts, Motors, Conveyors, Fans/Blowers, and more. The standard UDS1000 system includes the UDS1000 Speed Switch, a 906B Sensing Head, and a 255 Pulser Disc (shown above). Electro-Sensors' speed switches bring efficiency and safety to your operations by preventing machine damage, product waste, and costly downtime.

### Principle of Operation

The UDS1000 is equipped with a shaft-end mounted Pulser Disc (or optional split-collar Pulser Wrap) which generates an alternating magnetic field that is picked up by the large gap non-contact sensor. The sensor transmits this speed signal as a digital pulse (frequency) to the switch via a 4-conductor shielded cable. The UDS1000 decodes this frequency signal to determine shaft direction. The relay output can then be used for equipment shutdown, to prevent start-up, or to provide an alarm, assuring machine protection and process integrity. The UDS1000 is fail-safe; any malfunction during operation will de-energize the control circuit.

### Dimensional Drawings • USD 1000 Reverse Rotation Detector

#### Explosionproof UDS1000 Enclosure

(Stock No. 305-000600)

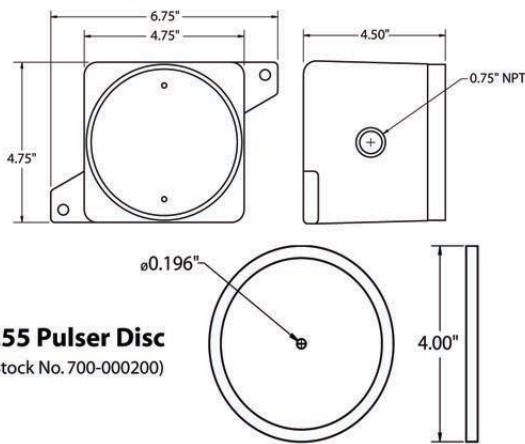

**255 Pulser Disc**  
(Stock No. 700-000200)

#### 906B Quadrature Sensor

(Stock No. 775-000504)

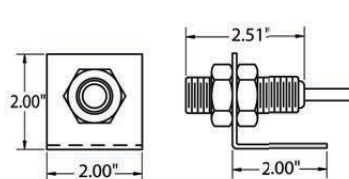

#### 907B Explosionproof Sensor

(Stock No. 775-006100 - vertical;  
Stock No. 775-006101 - horizontal)

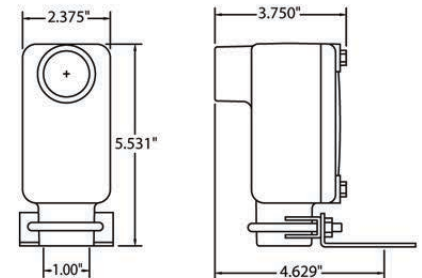

# UDS 1000 Speed Switch

## Large Gap Sensor Installation

The standard sensor is supplied with a mounting bracket and two jam nuts, and is easily adjustable to achieve the proper gap distance. The optional explosionproof sensor is supplied with a slotted mounting bracket, also easily adjustable. Sensors should be installed allowing the center of the magnets to pass in front of the center of the sensing head during rotation. The gap distance between the sensor and disc or wrap (Dimension A in Figures 1 and 2) is  $1/4" \pm 1/8"$ . When using a standard 4" Pulser Disc, the center of the magnetized area of the disc (Dimension B in Figure 1) is  $1-3/4"$  from the center hole of the disc.

## Available Options

- Explosionproof 907B vertical sensing head.
- Explosionproof 907B horizontal sensing head.
- Split collar pulser wrap for when end of shaft is inaccessible. Wraps available in the following materials:
  - PVC
  - Aluminum
  - Stainless steel.
- EZ100 Easy Mount Bracket Assembly for use with optional explosionproof sensor (figure 3 below)
- Stainless Steel Disc-Guard.

*(Consult factory for further options.)*

### Standard 906B Sensor and Disc\*

Figure 1

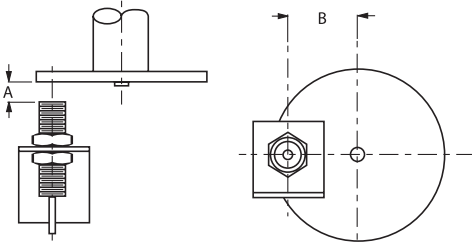

### Standard 906B Sensor and Wrap\*

Figure 2

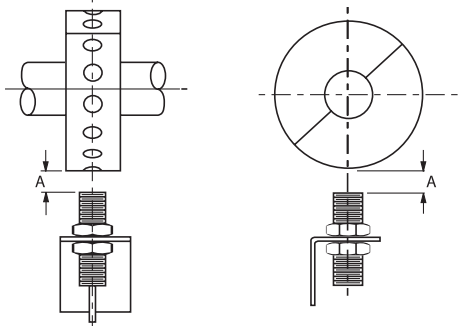

### Optional EZ-100 Easy Mount Bracket

Figure 3

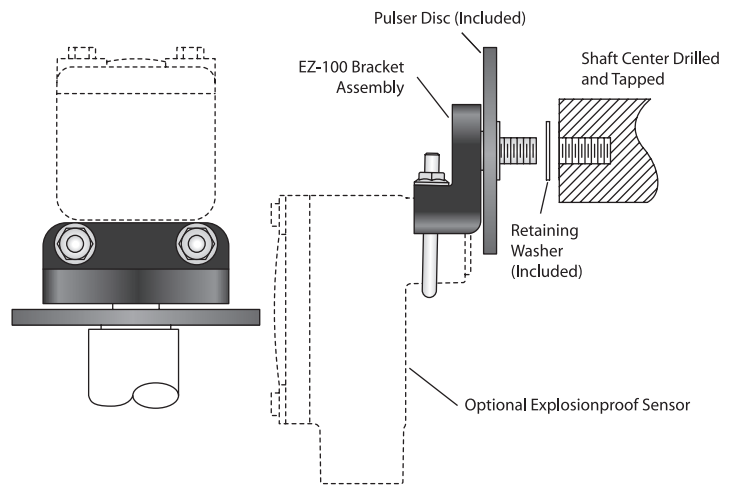

\* 907 Series Explosionproof Sensing Head is also compatible with discs and wraps.

## UDS1000 Specifications

### Input Power

Voltage ..... 115 Vac, 60 Hz std; 230 Vac,  
12 Vdc or 24 Vdc optional

### Sensor Input Signal

Type ..... Quadrature, NPN open collector  
Amplitude ..... 12 Vdc  
Pull-up ..... 2.2K Ohms  
Sensor Supply ..... 12 Vdc at 50 mA max  
Frequency Range ..... 0-666.67 Hz  
Set point relay ..... DPDT isolated, 5 Amp,  
115 Vac resistive

### General Specifications

Housing and cover ..... Cast aluminum, CSA approved, UL Rated: Class I - Group C, D; Class II - Group E, F, G; Class III; NEMA 4X  
906B Sensor ..... Aluminum 3/4"-16 UNF body with 10' of 4-conductor shielded cable  
907B Sensor ..... Cast aluminum, CSA approved, UL rated: Class I - Group D; Class II - Group E, F, G; Class III  
255 Pulser Disc ..... Nylon® 12, 4" diameter, 16 magnetic poles  
Gap distance .....  $1/4" \pm 1/8"$   
Operating Temperature .....  $-40^{\circ}\text{C}$  to  $+60^{\circ}\text{C}$ \*

*\*Contact factory for higher temperature ranges.  
Specifications subject to change without notice.*