

C310

Wall- / Pipe-mount universal process controller

C310 – gives you the control that you need wherever you need it



IP66/NEMA 4X wall- / pipe-mount housing

- no need for an instrument panel

Single output, heat / cool or motorized valve control

- one controller for every PID control application

9 program, 30 segment ramp / soak

- comprehensive set point profiling capabilities

Analog, relay and logic outputs as standard

- extensive control output requirements built-in

Universal process input with 0.1% accuracy

- direct connection of any process signal, simple installation without recalibration

RS485 Modbus serial communications

- SCADA, PLC and open systems integration



C310
Wall- / Pipe-mount universal process controller

C310

The C310 wall / pipe-mount universal process controller is a highly versatile single-loop controller packaged in a robust field-mounting housing.

No need to fit an expensive instrument panel when installing or upgrading process equipment. The C310 can be rapidly commissioned by simply fixing it to any flat surface or pipe and making the electrical connections via the cable entry glands on the underside of the unit.

The instrument has extensive control and i/o capabilities fitted as standard, allowing it to be rapidly configured for almost any application.

With IP66/NEMA4X water/dust protection the C310 can be mounted right next to your process, no matter how harsh the environment.

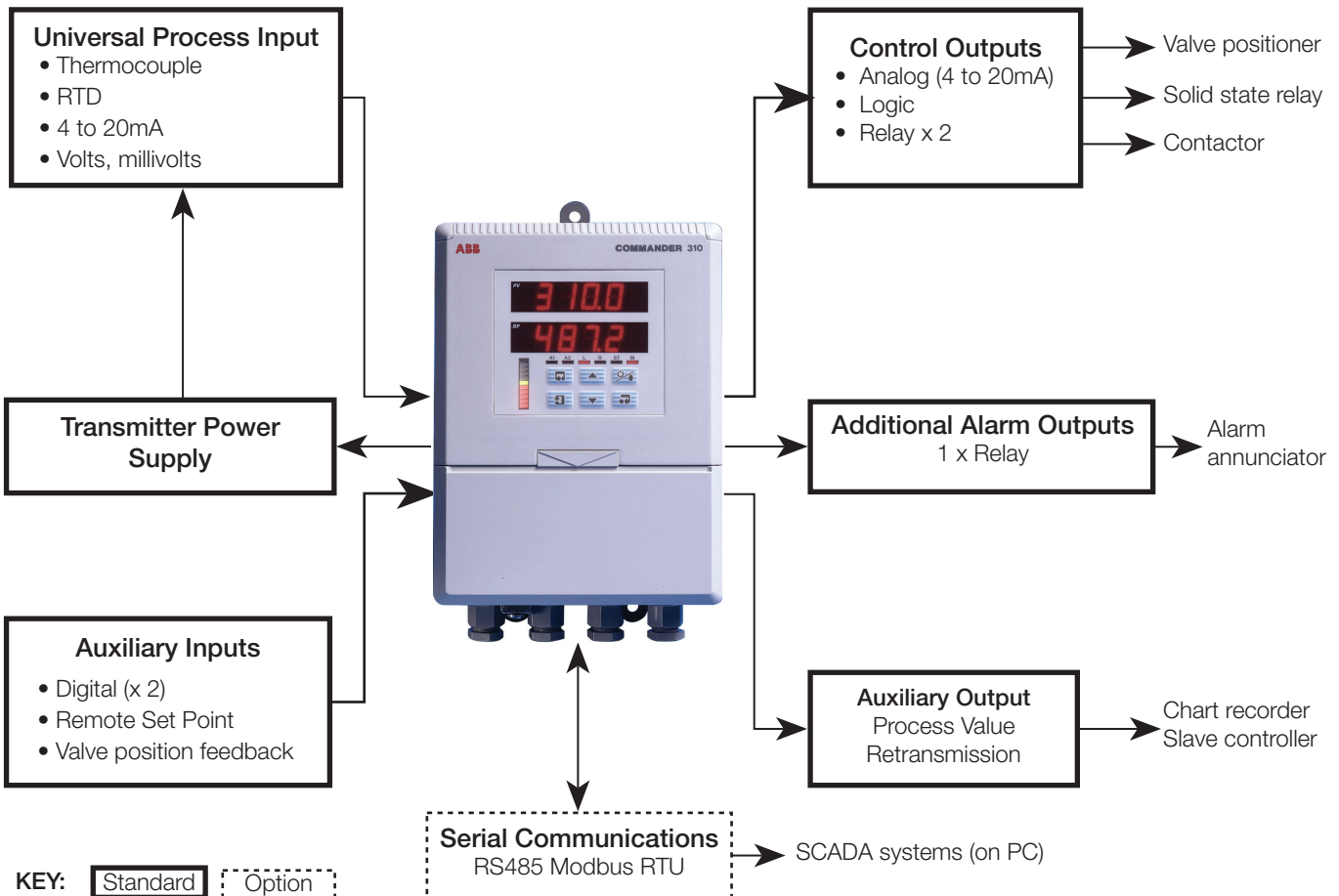

C310

Wall- / Pipe-mount universal process controller

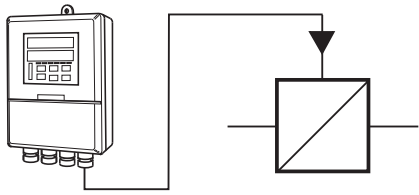

PID control

The C310's isolated analog output provides the standard control output to I/P converters, thyristors etc. Alternatively, built-in relays can be used to generate a time-proportioning control output.

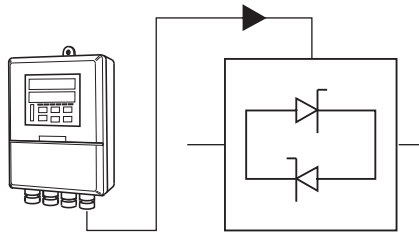

Solid state relay SSR

A 12V time-proportioning logic output on the standard C310 can be used to drive solid state relays (SSRs).

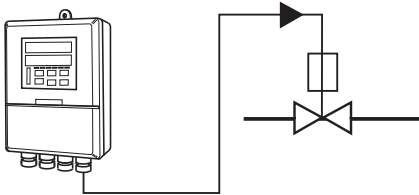

Valve position

The C310 is fitted with twin relays and a valve-position input for closed-loop control of a motorized valve. 'Boundless' control (without position feedback) and analog control (using 4 to 20mA output) are also available in the standard unit.

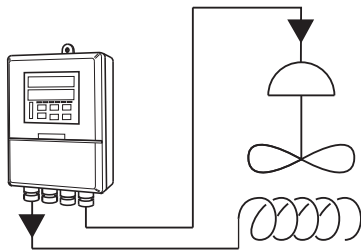

Heat / Cool

Heat/cool control strategies may be implemented on the standard C310, using a combination of the analog control output and one relay.

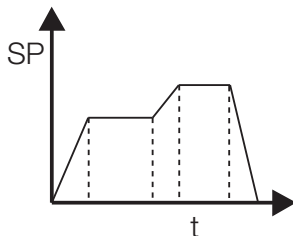

Ramp / Soak set point profiles

The standard ramp/soak facility provides 30 segments, freely assignable amongst 9 programs. A Segment Event function enables relays to be switched on or off at predetermined points within the program.

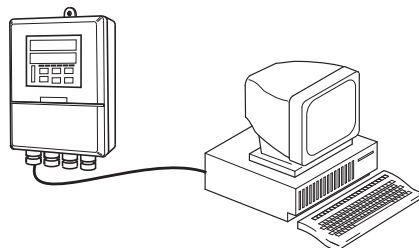

Serial communications

Not only does the C310 provide clear process information in the field, it can also communicate plant data to control rooms via an RS485 link, using Modbus protocol.



C310

Wall- / Pipe-mount universal process controller

Specification

Summary

C310 wall- / pipe-mount universal controller
P, PI, PID single loop controller
Autotune facility
Fully user configurable
IP66 (NEMA 4X) front face and housing

Operation

Display

High-intensity 7-segment, 0.56 in. (14mm), 2 x 6 red LED display

Configuration

User defined via front panel

Analog inputs

Number

3 universal process inputs

Type

Universally configurable for:

Channels 1 & 2 (Process Variable & Remote Set Point)	Thermocouple (THC) Resistance thermometer (RTD) Millivolt Current DC voltage Resistance
Channel 3 (Actuator Position Feedback)	DC voltage Current Resistance

Input sampling rate

160 ms per channel

Input impedance

Millivolts/THC	>10 MΩ
Voltage	500 kΩ
Current	10 Ω

Linearizer functions

Programmable for input channels 1 and 2
Sqrt, X^{3/2}, X^{5/2}, THC types B, E, J, K, R, S, T, L, N or Pt100

Broken sensor protection

Programmable Up/Downscale or None

Cold junction compensation

Automatic CJC incorporated as standard

Temperature limits

THC/RTD type Per NBS125 & IEC584	°C			°F		
	min.	max.	min. span	min.	max.	min. span
B	-18	1800	710	0	3272	1278
E	-100	900	45	-148	1652	81
J	-100	900	50	-148	1652	90
K	-100	1300	65	-148	2372	117
L	-100	900	50	-148	1652	90
N	-200	1300	90	-328	2372	162
R & S	-18	1700	320	0	3092	576
T	-250	300	60	418	572	108
RTD per DIN43760 & IEC751	-200	600	25	-328	1112	45

Notes.

Performance accuracy is not guaranteed below 400 °C (752 °F) for types B, R and S thermocouples.

RTD, 3-wire platinum, 100 Ω with range of 0 to 400 Ω

Min. span below zero Type T 70 °C (126 °F)
 Type N 105 °C (189 °F)

Electrical limits

Input type	Min. value	Max. value	Min. span
Millivolts	-2000	2000	2.5
Volts	-20	20	0.25
Milliamps	-100	100	0.25
Resistance	0	8000	10

Input noise rejection

Common mode rejection >140 dB at 50/60Hz with 500 Ω imbalance

Series mode rejection >60 dB at 50/60 Hz

Accuracy

Measurement error	<±0.1 % of reading or ±5 µV
Linearizer	Typically ±0.1 °C (±0.2 °F)
Display range	-9999 to 9999
CJC accuracy	<0.05 °C/°C change in ambient

Transmitter power supply

24 V 30 mA max. powers one loop, fitted as standard



C310

Wall- / Pipe-mount universal process controller

Outputs

Control output

Configurable as either:

Analog	in the range of 0 to 20 mA
Max. load	15 V (750 Ω at 20 mA)
Accuracy	≤ 0.1 % of span
Isolation	1 kV AC
Logic	12 V DC (SSR drive)
Max. load	400 Ω
Isolation	1kV AC

Retransmission

0 to 20mA configurable for process variable, set point or position feedback values

Max. load	15 V (750 Ω at 20 mA)
Accuracy	≤ 0.1 % of span

Relay outputs

3 relays, configurable for time proportioning control, valve drive or alarms.

SPDT 5A 120/240V AC normally open or normally closed

Option

Serial communications

Connections	RS485, 4-wire, 1.2k to 9.6k baud rate
Protocol	Modbus RTU

Electrical

Voltage

115 V $\pm 15\%$ or 230V $\pm 15\%$ 50/60Hz (link selectable)

Power consumption

<10 VA

Power interruption protection

<60 ms/<3 cycles, no effect

>60 ms/>3 cycles, controlled reset

Line interference

Meets IEC 801 Pt IV level 3 (>2kV spikes)

Environmental

Operating limits

-10 to 55 $^{\circ}\text{C}$ (14 to 131 $^{\circ}\text{F}$), 0 to 95 %RH non-condensing

Temperature stability

<0.02 % of reading or 1 $\mu\text{V} / ^{\circ}\text{C}$ (0.5 $\mu\text{V} / \text{L}^{\circ}\text{F}$)

Housing dust/water protection

IP66 (NEMA 4X)

RF protection

Meets IEC 801 Pt. III level 3

EMC

Emissions and Immunity

Meets requirements of IEC 61326 for an Industrial Environment

Design and manufacturing standards

CE

CSA/FM Class 1 Div.2 Hazardous Area



Dimensions

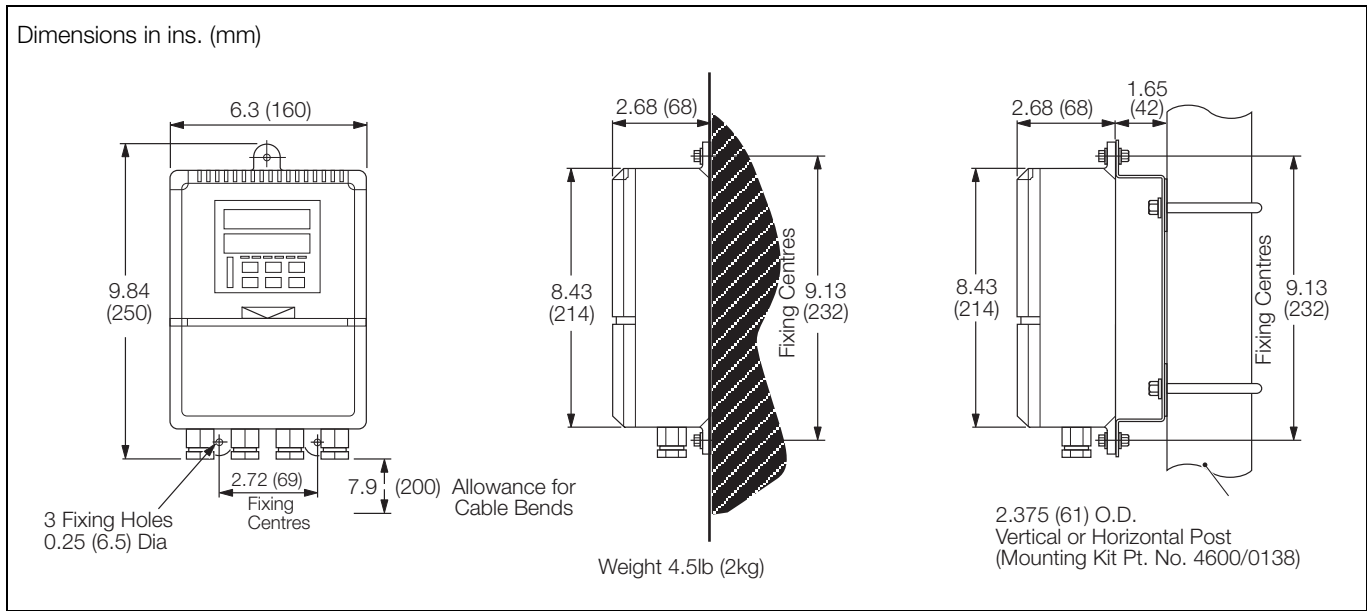

Electrical connections

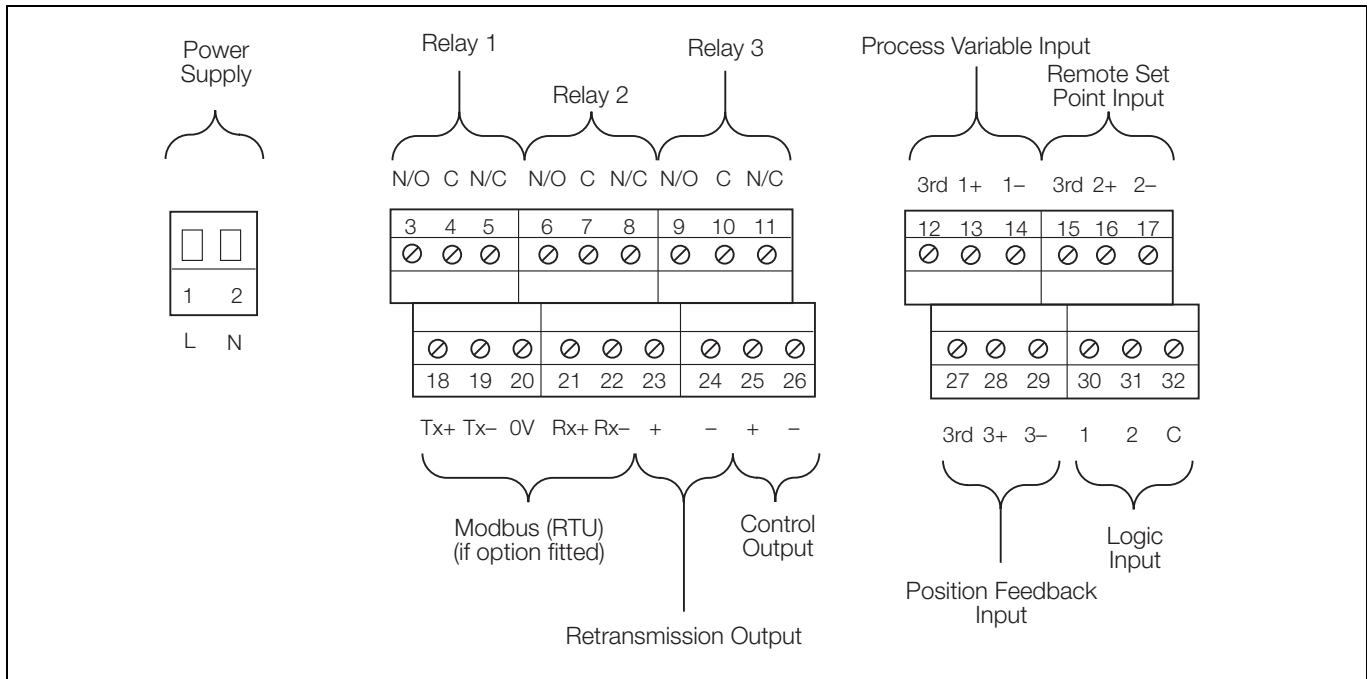

C310

Wall- / Pipe-mount universal process controller

Ordering information

C310 wall- / pipe-mount universal process controller	C310 /X	X	X	X/	XXXX
Option board					
None	0	0			
RS485 Modbus communications	0	1			
Power supply					
115V AC (NPT fitted with blanking plugs)				1	
230V AC (M20 fitted with cable glands)				2	
115V AC (M20 fitted with cable glands)				4	
230V AC (NPT fitted with blanking plugs)				5	
Build					
Standard					0
CSA/FM Class 1 Division 2					3
Programming / Special features					
Configured to factory standard					STD
Configured to customer requirements (customer to complete and supply C310 custom configuration sheet – INF12/111-EN)					CUS
Agreed special features					SXX
Engineered configuration (customer to supply configuration details required)					ENG

Instrument coding example

	C310 /	01	1	3 /	STD
C310 Controller	_____	_____	_____	_____	_____
RS485 Modbus Communications	_____	_____	_____	_____	_____
115 V AC	_____	_____	_____	_____	_____
CSA/FM Class 1 Division 2	_____	_____	_____	_____	_____
Factory standard configuration	_____	_____	_____	_____	_____

Accessories

Pipe mount kit	4600/0138
After-sales engineered configuration service	ENG/CON

